



Ferrites and accessories

RM 8, RM 8 LP
Cores and accessories

Series/Type: B65811, B65812
Date: September 2006/October 2007

- To IEC 62317-4
- Cores without center hole for transformer applications
- Delivery mode: sets

Magnetic characteristics (per set)

	with center hole	without center hole	
$\Sigma l/A$	0.68	0.59	mm ⁻¹
l_e	35.1	38	mm
A_e	52	64	mm ²
A_{min}	—	55	mm ²
V_e	1825	2430	mm ³

Approx. weight (per set)

m	10.7	12	g

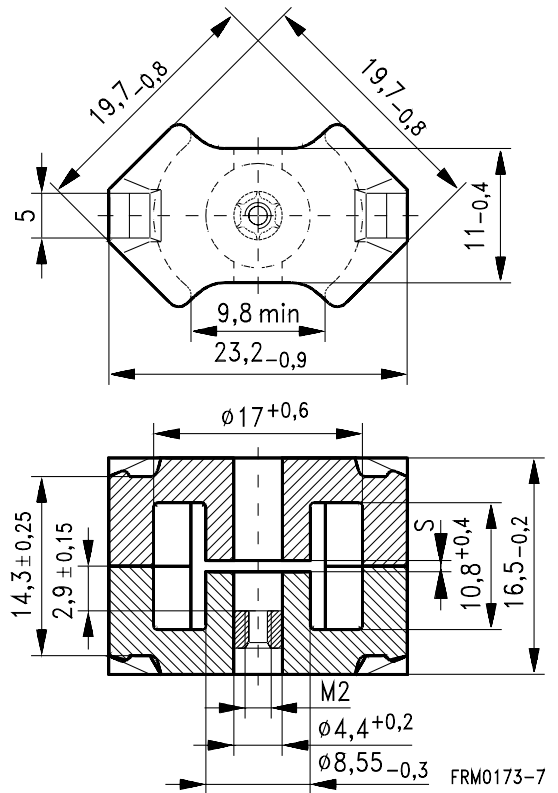
Gapped

Material	A_L value nH	s approx. mm	μ_e	Ordering code ¹⁾ -D with center hole -F with threaded sleeve -J without center hole
N48	250 \pm 3%	0.23	134	B65811+0250A048
	315 \pm 3%	0.17	169	B65811+0315A048
	400 \pm 3%	0.14	215	B65811+0400A048
	630 \pm 5%	0.10	338	B65811+0630J048
N41	160 \pm 3%	0.49	76	B65811J0160A041
	250 \pm 5%	0.24	118	B65811J0250J041
	630 \pm 5%	0.11	298	B65811J0630J041
	1600 \pm 10%	0.04	756	B65811J1600K041
N87	250 \pm 3%	0.30	118	B65811J0250A087
	400 \pm 3%	0.18	189	B65811J0400A087

1) Replace the + by the code letter "F" or "D" for the required version. Standard version is "D".

Ungapped

Material	A _L value nH	μ _e	P _V W/set	Ordering code -D with center hole -J without center hole
N48	2900 +30/-20%	1550		B65811D0000R048
N30	5700 +30/-20%	2690		B65811J0000R030
T38	12500 +40/-30%	5910		B65811J0000Y038
N49	2200 +30/-20%	1040	< 0.37 (50 mT, 500 kHz, 100 °C)	B65811J0000R049
N87	3300 +30/-20%	1560	< 1.20 (200 mT, 100 kHz, 100 °C)	B65811J0000R087
N97	3300 +30/-20%	1560	< 1.00 (200 mT, 100 kHz, 100 °C)	B65811J0000R097
N41	4100 +30/-20%	1940	< 0.37 (200 mT, 25 kHz, 100 °C)	B65811J0000R041

Coil former, squared pins

Material: GFR thermosetting plastic (UL 94 V-0, insulation class to IEC 60085: H \triangleq max. operating temperature 180 °C), color code black
Sumikon PM 9630® [E41429 (M)], SUMITOMO BAKELITE CO LTD

Solderability: to IEC 60068-2-20, test Ta, method 1 (aging 3): 235 °C, 2 s

Resistance to soldering heat: to IEC 60068-2-20, test Tb, method 1B: 350 °C, 3.5 s

Winding: see Data Book 2007, chapter "Processing notes, 2.1"

For matching clamp and insulating washers see page 8.

Sections	A_N mm ²	l_N mm	A_R value $\mu\Omega$	Pins	Ordering code
1	30	42	47	5	B65812N1005D001
				8	B65812N1008D001
				12	B65812N1012D001
2	28.4	42	50	5	B65812N1005D002

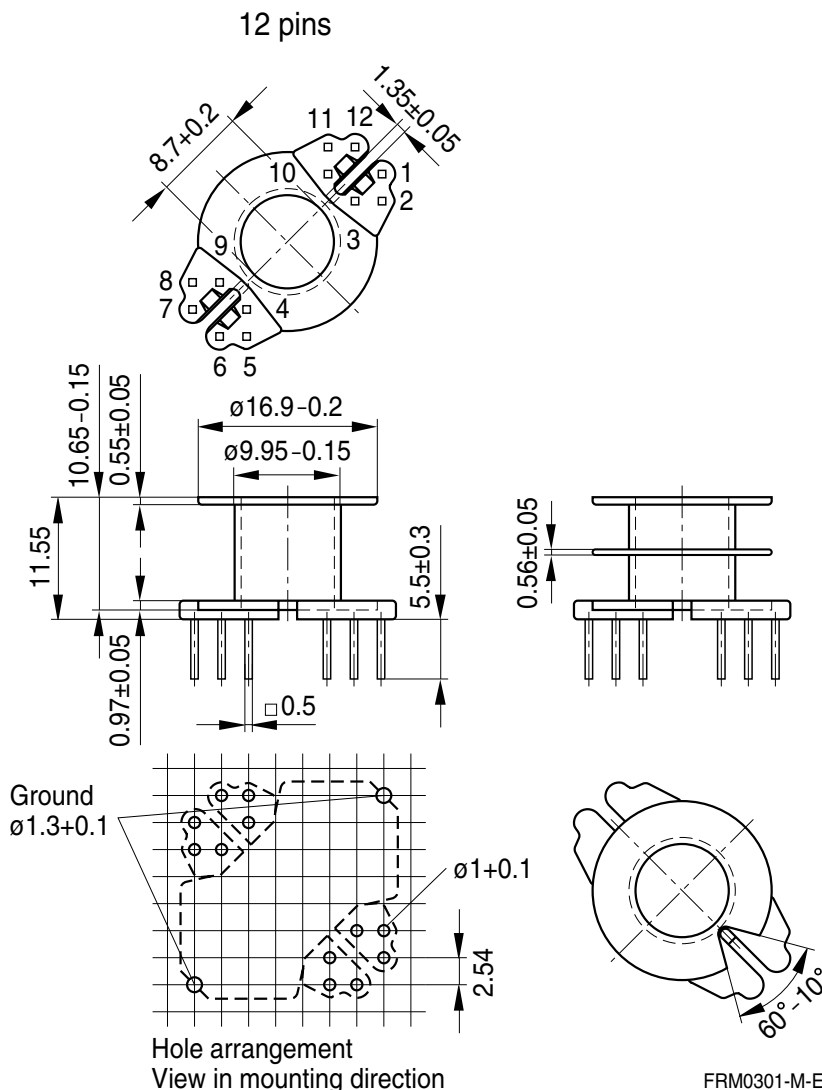

Version	Pins omitted
5 pins	3, 4, 6, 7, 9, 10, 12
8 pins	3, 4, 9, 10

Coil former, pins squared in the start-of-winding area

Material: GFR thermosetting plastic (UL 94 V-0, insulation class to IEC 60085:
 $H \triangleq$ max. operating temperature 180 °C), color code blue
 Bakelite UP 3420® [E61040 (M)], HEXION SPECIALTY CHEMICALS GMBH

Solderability: to IEC 60068-2-20, test Ta, method 1 (aging 3): 235 °C, 2 s

Resistance to soldering heat: to IEC 60068-2-20, test Tb, method 1B: 350 °C, 3.5 s

Winding: see Data Book 2007, chapter "Processing notes, 2.1"

For matching clamp and insulating washers see page 8.

Sections	A_N mm ²	l_N mm	A_R value $\mu\Omega$	Pins	Ordering code
1	30	42	47	5	B65812K1005D001
				8	B65812K1008D001
				12	B65812K1012D001
2	28.4	42	50	8	B65812K1008D002

12 pins

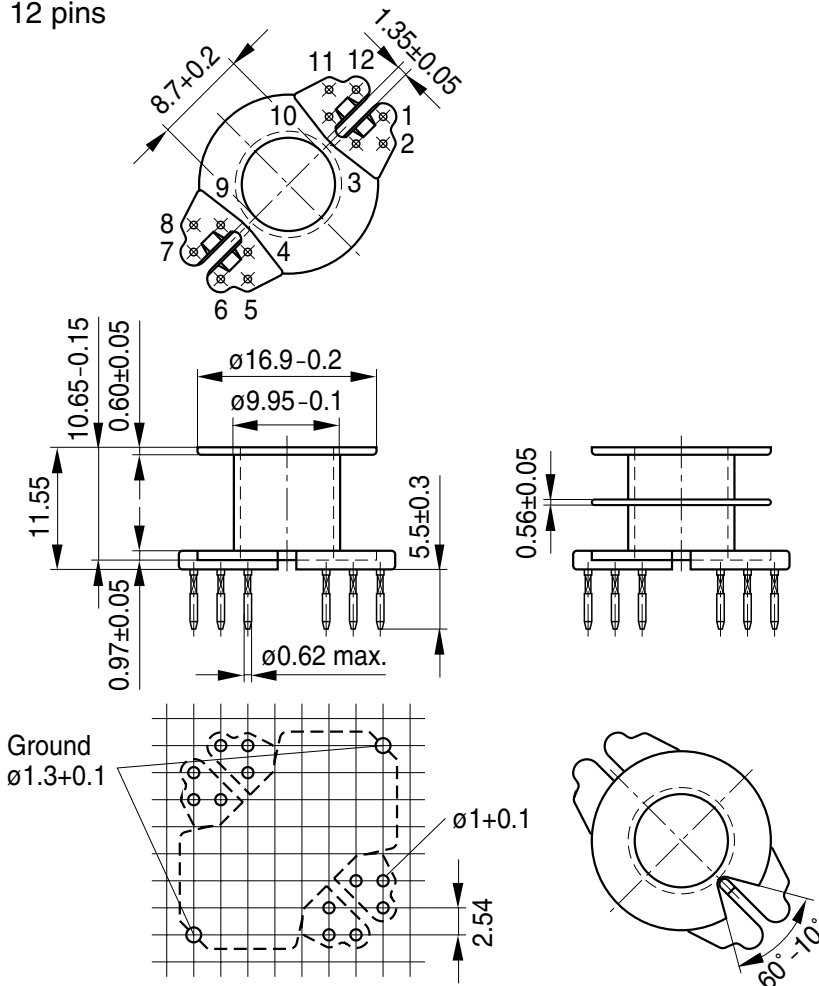

Version	Pins omitted
5 pins	3, 4, 6, 7, 9, 10, 12
8 pins	3, 4, 9, 10

Hole arrangement
View in mounting direction

FRM0240-2

Coil former for SMPS transformers with line isolation

The creepage distances and clearances are designed such that the coil former is suitable for use in SMPS transformers with line isolation.

- Closed center flange with external wire guide
- Pins squared in the start-of-winding area
- Optimized for use with automatic winding machines

Material: GFR thermosetting plastic (UL 94 V-0, insulation class to IEC 60085: F \triangleq max. operating temperature 155 °C), color code green
 Vyncolit/X611® [E167521 (M)], VYNCOLIT NV

Solderability: to IEC 60068-2-20, test Ta, method 1 (aging 3): 235 °C, 2 s

Resistance to soldering heat: to IEC 60068-2-20, test Tb, method 1B: 350 °C, 3.5 s

Winding: see Data Book 2007, chapter "Processing notes, 2.1"

Sections	A _N mm ²	l _N mm	A _R value μΩ	Pins	Ordering code
2	28.4	42	50	8	B65812X1108D002

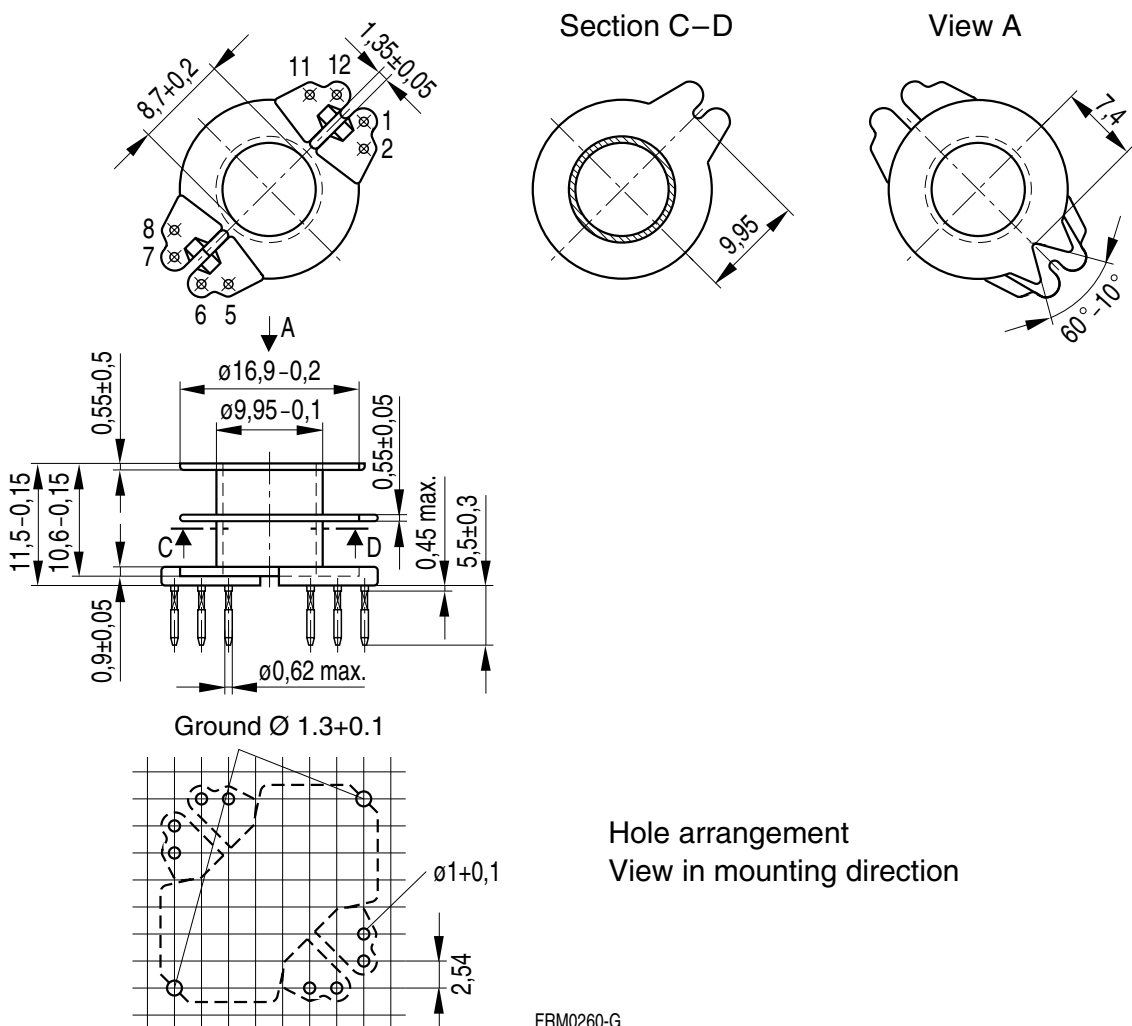

Coil former for power applications

Optimized for automatic winding

 Material: GFR polyterephthalate (UL 94 V-0, insulation class to IEC 60085:
 $F \triangleq$ max. operating temperature 155 °C), color code black
 Valox 420-SE0® [E45329 (M)], GE PLASTICS B V

Solderability: to IEC 60068-2-20, test Ta, method 1 (aging 3): 235 °C, 2 s

Resistance to soldering heat: to IEC 60068-2-20, test Tb, method 1B: 350 °C, 3.5 s

Winding: see Data Book 2007, chapter "Processing notes, 2.1"

For matching clamp and insulating washer 1 see page 8.

Sections	A_N mm ²	l_N mm	A_R value $\mu\Omega$	Pins	Ordering code
1	30	42	47	12	B65812C1512T001

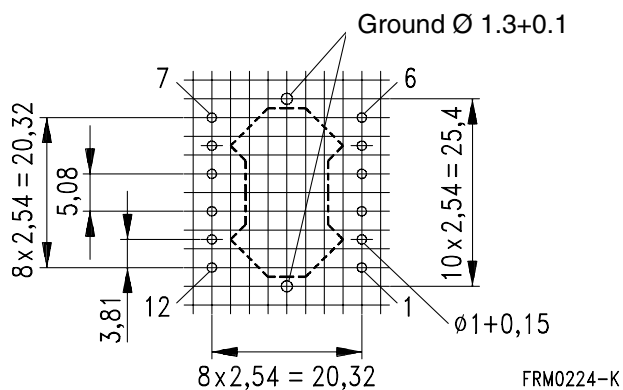
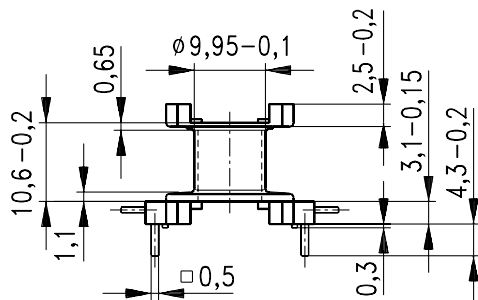
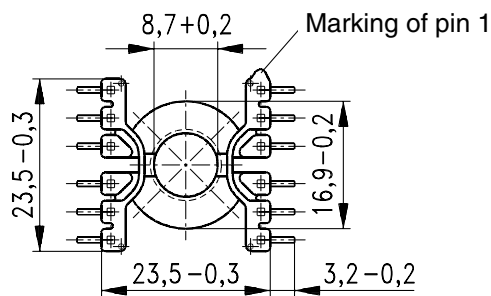

Hole arrangement
 View in mounting direction
 (Note half pitch!)

Clamp

- With ground terminal, made of stainless spring steel (tinned), 0.4 mm thick
- Solderability to IEC 60068-2-20, test Ta, method 1 (aging 3): 235 °C, 2 s
- Also available as strip clamp on reels on request

Insulating washer 1 between core and coil former

- For tolerance compensation and for insulation
- Made of polycarbonate (UL 94 V-0, insulation class to IEC 60085: E \geq 120 °C), 0.08 mm thick Aryphan F685, [E167358 (M)], natural color, LOFO HIGH TECH FILM GMBH

Insulating washer 2 for double-clad PCBs

- Made of polycarbonate (UL 94 V-0, insulation class to IEC 60085: E \geq 120 °C), 0.3 mm thick Makrofol FR, [E118859 (M)], natural color, BAYER MATERIALSCIENCE L L C

	Ordering code
Clamp (ordering code per piece, 2 are required)	B65812A2203X000
Insulating washer 1 (reel packing, PU = 1 reel)	B65812A5000X000
Insulating washer 2 (bulk)	B65812C2005X000

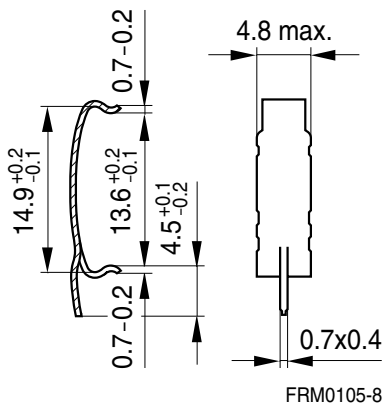
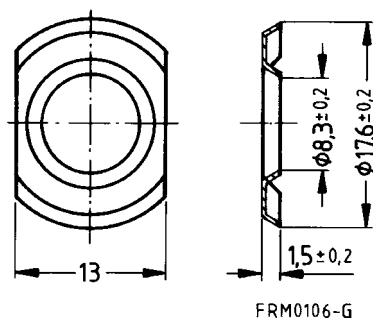
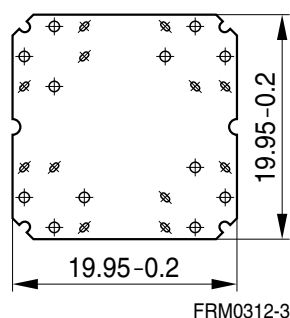
Clamp

Insulating washer 1
(preliminary data)

Insulating washer 2

Adjusting screw

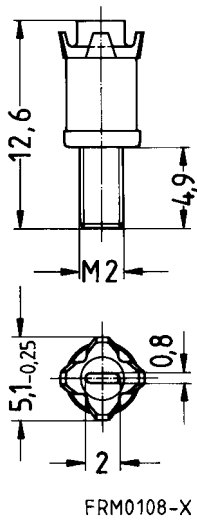
- Tube core with thread and core brake made of GFR polyterephthalate
Pocan B3235® [E245249 (M)], LANXESS AG

Tube core Ø × length (mm)	Material	Color code	Ordering code
3.85 × 5.0	N22	gray	B65812B3003X022



RM 8 »Low Profile«
Core
B65811P

- To IEC 62317-4
- For compact transformers
- Without center hole
- Delivery mode: sets

Magnetic characteristics (per set)

$$\Sigma l/A = 0.44 \text{ mm}^{-1}$$

$$l_e = 28.7 \text{ mm}$$

$$A_e = 64.9 \text{ mm}^2$$

$$A_{\text{min}} = 55.4 \text{ mm}^2$$

$$V_e = 1860 \text{ mm}^3$$

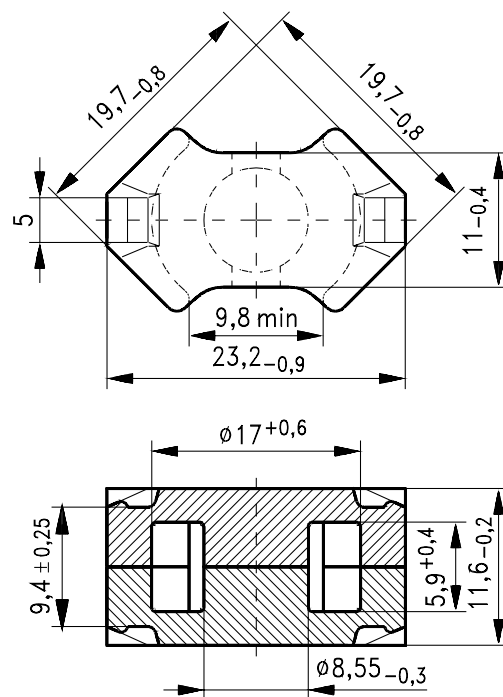
Approx. weight 9.2 g/set

FRM0174-F

Ungapped

Material	A _L value	μ_e	P _V	Ordering code
	nH		W/set	
N49	2900 +30/-20%	1020	< 0.33 (50 mT, 500 kHz, 100 °C)	B65811P0000R049
N92	3100 +30/-20%	1090	< 1.10 (200 mT, 100 kHz, 100 °C)	B65811P0000R092
N87	4100 +30/-20%	1440	< 0.92 (200 mT, 100 kHz, 100 °C)	B65811P0000R087

Clamp

- With ground terminal, made of stainless spring steel (tinned), 0.4 mm thick
- Solderability to IEC 60068-2-20, test Ta, method 1 (aging 3): 235 °C, 2 s
- Also available as strip clamp on reels on request

Insulating washer 1 between core and coil former

- For tolerance compensation and for insulation
- Made of polycarbonate (UL 94 V-0, insulation class to IEC 60085: E \geq 120 °C), 0.08 mm thick Aryphan F685, [E167358 (M)], natural color, LOFO HIGH TECH FILM GMBH

Insulating washer 2 for double-clad PCBs

- Made of polycarbonate (UL 94 V-0, insulation class to IEC 60085: E \geq 120 °C), 0.3 mm thick Makrofol FR, [E118859 (M)], natural color, BAYER MATERIALSCIENCE L L C

	Ordering code
Clamp (ordering code per piece, 2 are required)	B65812P2203X000
Insulating washer 1 (reel packing, PU = 1 reel)	B65812A5000X000
Insulating washer 2 (bulk)	B65812C2005X000

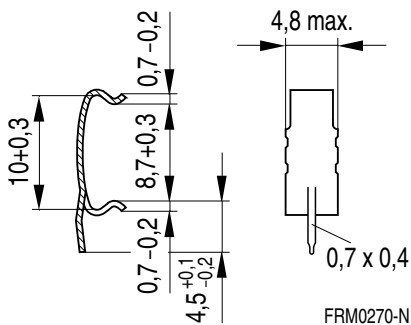
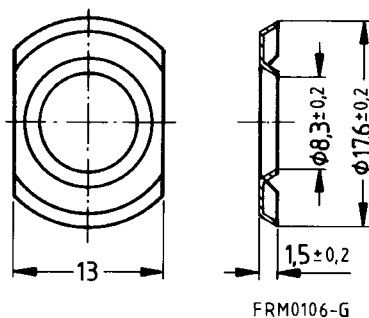
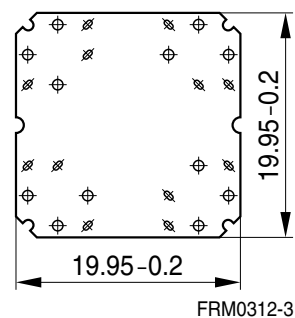
Clamp

Insulating washer 1
(preliminary data)

Insulating washer 2

Mechanical stress and mounting

Ferrite cores have to meet mechanical requirements during assembling and for a growing number of applications. Since ferrites are ceramic materials one has to be aware of the special behavior under mechanical load.

As valid for any ceramic material, ferrite cores are brittle and sensitive to any shock, fast changing or tensile load. Especially high cooling rates under ultrasonic cleaning and high static or cyclic loads can cause cracks or failure of the ferrite cores.

For detailed information see Data Book 2007, chapter “General – Definitions, 8.1”.

Effects of core combination on A_L value

Stresses in the core affect not only the mechanical but also the magnetic properties. It is apparent that the initial permeability is dependent on the stress state of the core. The higher the stresses are in the core, the lower is the value for the initial permeability. Thus the embedding medium should have the greatest possible elasticity.

For detailed information see Data Book 2007, chapter “General – Definitions, 8.2”.

Heating up

Ferrites can run hot during operation at higher flux densities and higher frequencies.

NiZn-materials

The magnetic properties of NiZn-materials can change irreversible in high magnetic fields.

Processing notes

- The start of the winding process should be soft. Else the flanges may be destroyed.
- To strong winding forces may blast the flanges or squeeze the tube that the cores can no more be mount.
- To long soldering time at high temperature (>300 °C) may effect coplanarity or pin arrangement.
- Not following the processing notes for soldering of the J-leg terminals may cause solderability problems at the transformer because of pollution with Sn oxyd of the tin bath or burned insulation of the wire. For detailed information see Data Book 2007, chapter “Processing notes, 2.2”.
- The dimensions of the hole arrangement have fixed values and should be understood as a recommendation for drilling the printed circuit board. For dimensioning the pins, the group of holes can only be seen under certain conditions, as they fit into the given hole arrangement. To avoid problems when mounting the transformer, the manufacturing tolerances for positioning the customers’ drilling process must be considered by increasing the hole diameter.

Important notes

The following applies to all products named in this publication:

1. Some parts of this publication contain **statements about the suitability of our products for certain areas of application**. These statements are based on our knowledge of typical requirements that are often placed on our products in the areas of application concerned. We nevertheless expressly point out **that such statements cannot be regarded as binding statements about the suitability of our products for a particular customer application**. As a rule, EPCOS is either unfamiliar with individual customer applications or less familiar with them than the customers themselves. For these reasons, it is always ultimately incumbent on the customer to check and decide whether an EPCOS product with the properties described in the product specification is suitable for use in a particular customer application.
2. We also point out that **in individual cases, a malfunction of electronic components or failure before the end of their usual service life cannot be completely ruled out in the current state of the art, even if they are operated as specified**. In customer applications requiring a very high level of operational safety and especially in customer applications in which the malfunction or failure of an electronic component could endanger human life or health (e.g. in accident prevention or life-saving systems), it must therefore be ensured by means of suitable design of the customer application or other action taken by the customer (e.g. installation of protective circuitry or redundancy) that no injury or damage is sustained by third parties in the event of malfunction or failure of an electronic component.
3. **The warnings, cautions and product-specific notes must be observed.**
4. In order to satisfy certain technical requirements, **some of the products described in this publication may contain substances subject to restrictions in certain jurisdictions (e.g. because they are classed as hazardous)**. Useful information on this will be found in our Material Data Sheets on the Internet (www.epcos.com/material). Should you have any more detailed questions, please contact our sales offices.
5. We constantly strive to improve our products. Consequently, **the products described in this publication may change from time to time**. The same is true of the corresponding product specifications. Please check therefore to what extent product descriptions and specifications contained in this publication are still applicable before or when you place an order.
We also **reserve the right to discontinue production and delivery of products**. Consequently, we cannot guarantee that all products named in this publication will always be available.
6. Unless otherwise agreed in individual contracts, **all orders are subject to the current version of the “General Terms of Delivery for Products and Services in the Electrical Industry” published by the German Electrical and Electronics Industry Association (ZVEI)**.
7. The trade names EPCOS, BAOKE, Alu-X, CeraDiode, CSSP, MiniBlue, MKK, MLSC, MotorCap, PCC, PhaseCap, PhaseMod, SIFERRIT, SIFI, SIKOREL, SilverCap, SIMDAD, SIMID, SineFormer, SIOV, SIP5D, SIP5K, ThermoFuse, WindCap are **trademarks registered or pending** in Europe and in other countries. Further information will be found on the Internet at www.epcos.com/trademarks.