

Features

- Max Junction Temperature 175°C
- High breakdown voltage up to 650V for improved reliability
- Short Circuit Rated
- Very Low Saturation Voltage:
 $V_{CE(SAT)} = 1.50V$ (Typ.) @ $I_C = 15A$
- Soft current turn-off waveforms

V_{CE}	650	V
I_C	15	A
$V_{CE(SAT)} I_C=15A$	1.50	V

Applications

- Soft switching applications
- Air conditioning
- Motor drive inverter

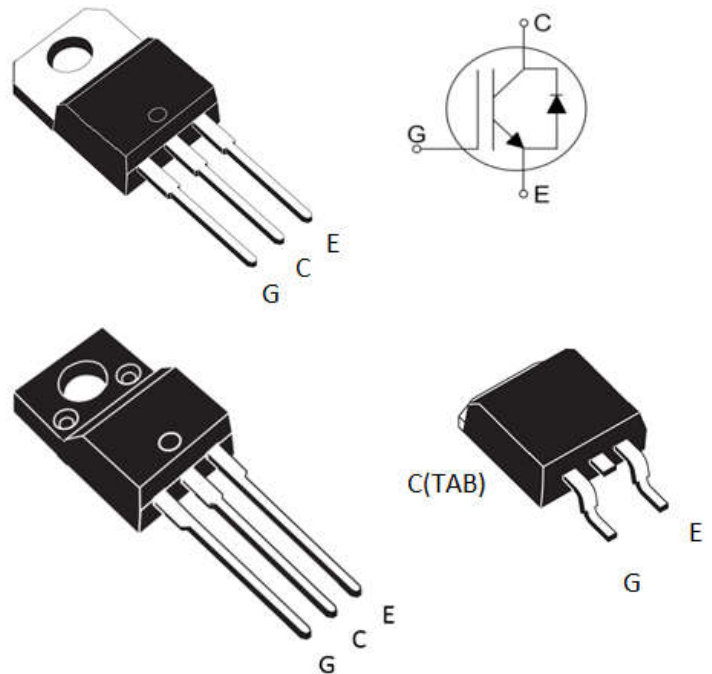

Product	Package	Packaging
YGF15N65T2	TO-220F	Tube
YGP15N65T2	TO-220	Tube
YGK15N65T2	TO-263	Tape and reel

Maximum Ratings ($T_j = 25^\circ\text{C}$ unless otherwise specified)

Parameter	Symbol	Value	Unit
Collector-Emitter Breakdown Voltage	V_{CE}	650	V
DC collector current, limited by T_{jmax} $T_C = 25^\circ\text{C}$ $T_C = 100^\circ\text{C}$	I_C	30 15	A
Diode Forward current, limited by T_{jmax} $T_C = 25^\circ\text{C}$ $T_C = 100^\circ\text{C}$	I_F	30 15	A
Continuous Gate-emitter voltage	V_{GE}	± 20	V
Transient Gate-emitter voltage	V_{GE}	± 30	V
Turn off safe operating area $V_{CE} \leq 650\text{V}$, $T_j \leq 175^\circ\text{C}$	-	60	A
Pulsed collector current, $V_{GE} = 15\text{V}$, t_p limited by T_{jmax}	I_{CM}	60	A
Short Circuit Withstand Time, $V_{GE} = 15\text{V}$, $V_{CE} \leq 400\text{V}$	T_{sc}	5	μs
TO-220F Power dissipation, $T_j = 25^\circ\text{C}$	P_{tot}	30.6	W
TO-220, TO-263, Power dissipation, $T_j = 25^\circ\text{C}$	P_{tot}	125	W
Operating junction temperature	T_j	$-40 \dots +175$	$^\circ\text{C}$
Storage temperature	T_s	$-55 \dots +175$	$^\circ\text{C}$
Soldering temperature, wave soldering 1.6mm (0.063in.) from case for 10s	-	260	$^\circ\text{C}$
Mounting torque, M3 screw Maximum of mounting processes: 3	M	0.6	Nm

Thermal Resistance

Parameter	Symbol	TO-220F	TO-220, TO-263	Unit
IGBT thermal resistance, junction - case	$R_{\theta(j-c)}$	4.9	1.2	K/W
Diode thermal resistance, junction - case	$R_{\theta(j-c)}$	5.8	2.38	K/W
Thermal resistance, junction - ambient	$R_{\theta(j-a)}$	62.5		K/W

Electrical Characteristics of the IGBT ($T_j = 25^\circ\text{C}$ unless otherwise specified)

Symbol	Parameter	Test Conditions	Min.	Typ.	Max.	Units
Static Characteristics (Tested on wafers)						
BV_{CES}	Collector to Emitter Breakdown Voltage	$V_{GE} = 0V, I_C = 1mA$	650	-	-	V
$V_{CE(SAT)}$	Collector to Emitter Saturation Voltage	$I_C = 15A, V_{GE} = 15V$	-	1.50	1.9	V
$V_{GE(th)}$	G-E Threshold Voltage	$V_{GE} = V_{CE}, I_C = 250\mu A$	4.4	5.4	6.4	V
I_{CES}	Collector Cut-Off Current	$V_{CE} = 650V, V_{GE} = 0V$	-	-	40	μA
I_{GES}	G-E Leakage Current	$V_{GE} = \pm 20V, V_{CE} = 0V$	-	-	± 200	nA
g_{fs}	Transconductance	$V_{CE}=20V, I_C=15A$	-	10	-	S

Parameter	Symbol	Conditions	Min	Typ	Max	Unit
Dynamic						
Input capacitance	C_{ies}	$V_{CE} = 25V, V_{GE} = 0V,$ $f = 1MHz$	-	1050	-	pF
Output capacitance	C_{oes}		-	50	-	
Reverse transfer capacitance	C_{res}		-	20	-	
Gate charge	Q_G	$V_{CC} = 520V, I_C = 15A,$ $V_{GE} = 15V$	-	45	-	nC
Short circuit collector current	$I_{C(SC)}$	$V_{GE}=15V, t_{SC} \leq 5\mu s$ $V_{CC}=400V,$ $T_{j, start}=25^\circ C$	-	150	-	A

Switching Characteristic, Inductive Load ($T_j = 25^\circ\text{C}$ unless otherwise specified)

Parameter	Symbol	Conditions	Min.	Typ.	Max.	Unit
Dynamic						
Turn-on Delay Time	$t_{d(on)}$	$T_j = 25^\circ\text{C}$ $V_{CC} = 400\text{V}$, $I_C = 20\text{A}$, $V_{GE} = 0/15\text{V}$, $R_g = 20\Omega$	-	20	-	ns
Rise Time	t_r		-	20	-	ns
Turn-off Delay Time	$t_{d(off)}$		-	65	-	ns
Fall Time	t_f		-	85	-	ns
Turn-on Energy	E_{on}		-	0.42	-	mJ
Turn-off Energy	E_{off}		-	0.09	-	mJ

Electrical Characteristics of the DIODE ($T_j = 25^\circ\text{C}$ unless otherwise specified)

Parameter	Symbol	Conditions	Min	Typ	Max	Unit
Dynamic						
Diode Forward Voltage	V_{FM}	$I_F = 15\text{A}$	-	1.8	-	V
Reverse Recovery Time	T_{rr}	$I_F = 15\text{A}$ $V_R = 300\text{V}$, $di/dt = 200\text{A}/\mu\text{s}$	-	50	-	ns
Reverse Recovery Current	I_{rr}		-	4	-	A
Reverse Recovery Charge	Q_{rr}		-	83	-	nC

Fig. 1 FBSOA characteristics for TO-220F

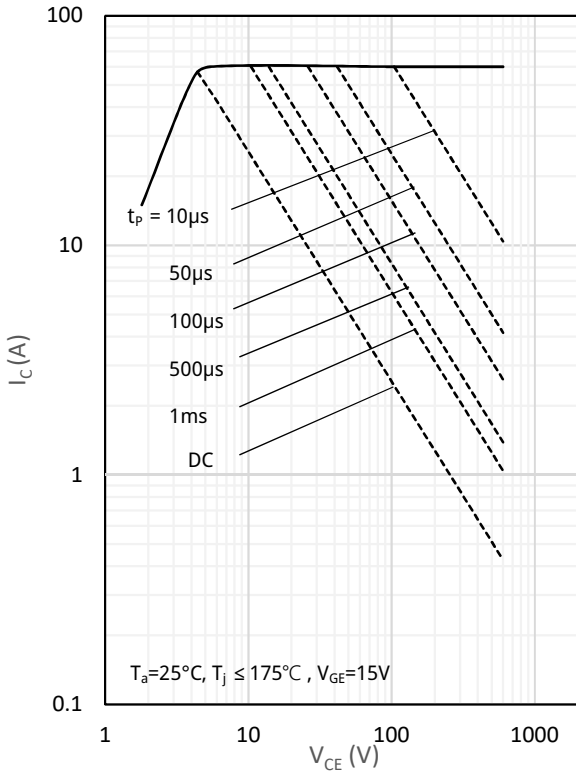

Fig. 2 FBSOA characteristics for TO-220 and TO-263

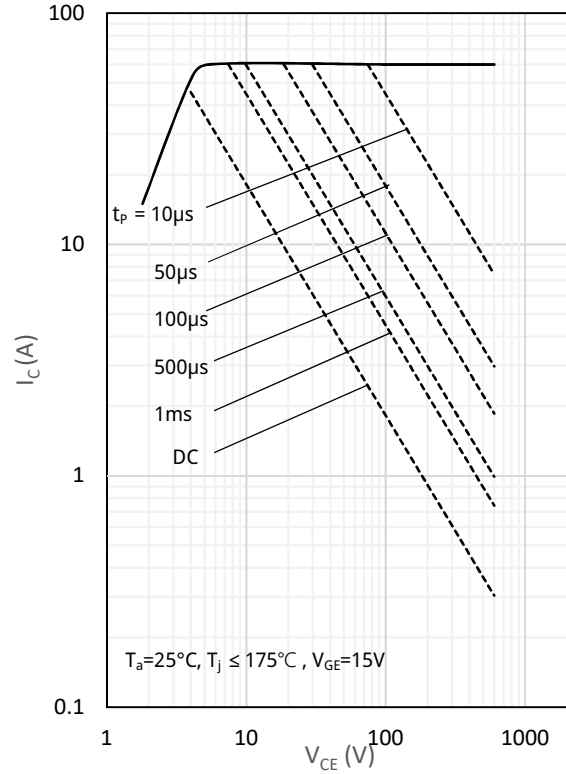

Fig. 3 Load Current vs. Frequency for TO-220F

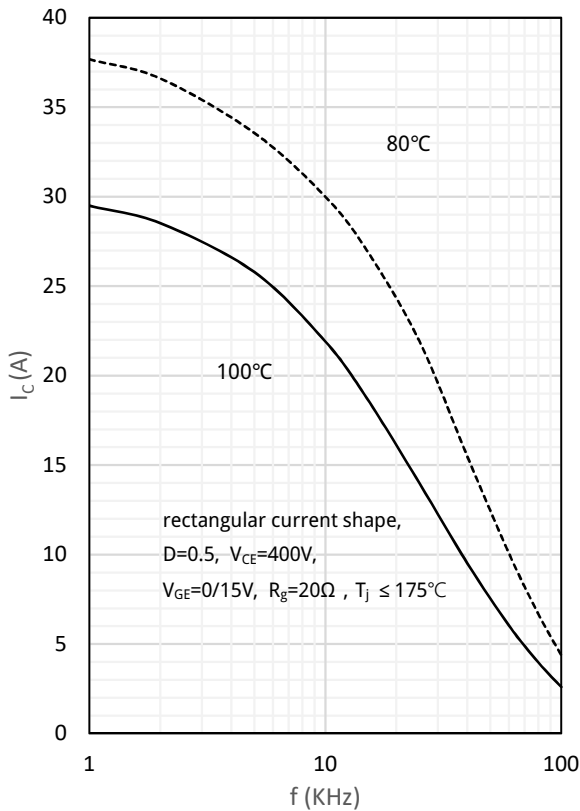

Fig.4 Load Current vs. Frequency TO-220 and TO-263

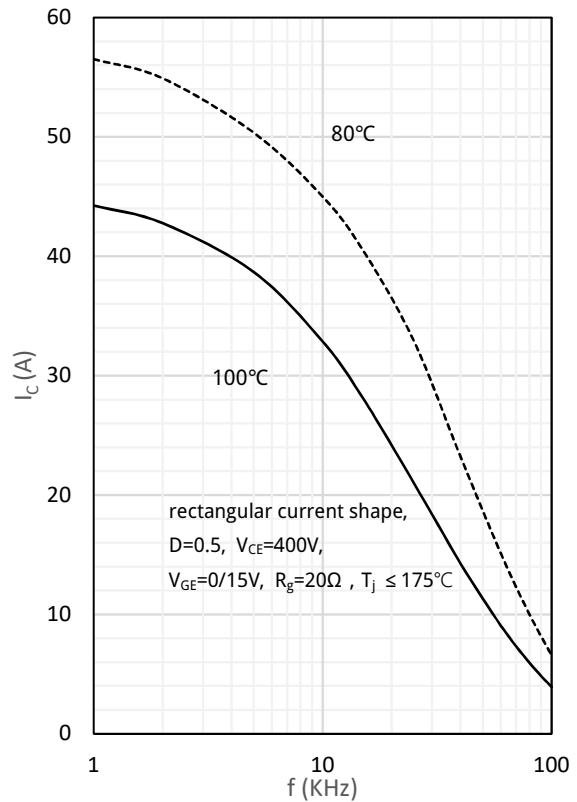

Fig. 5 Output characteristics

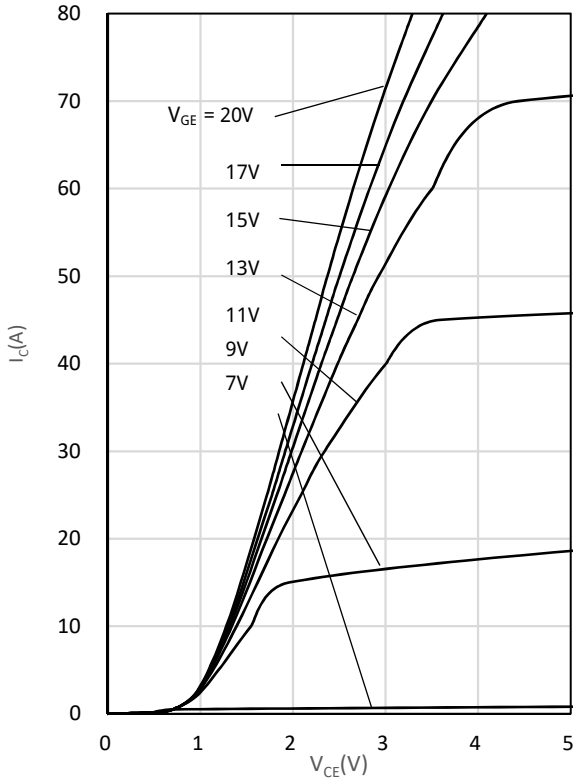

Fig. 6 Saturation voltage characteristics

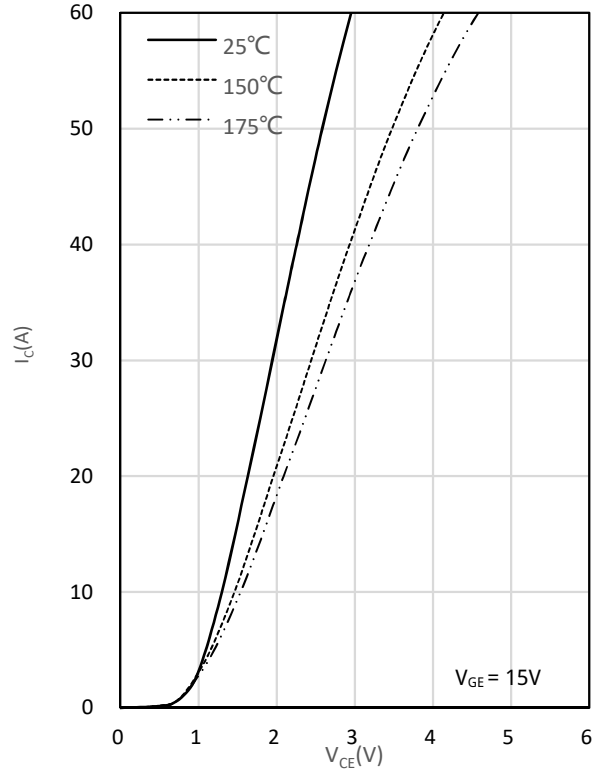

Fig. 7 Switching times vs. gate resistor

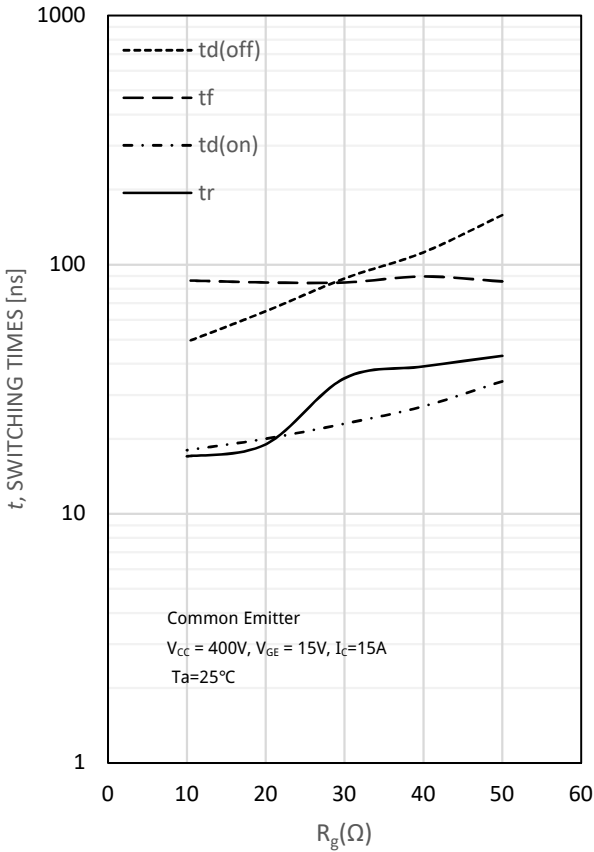

Fig. 8 Switching times vs. collector current

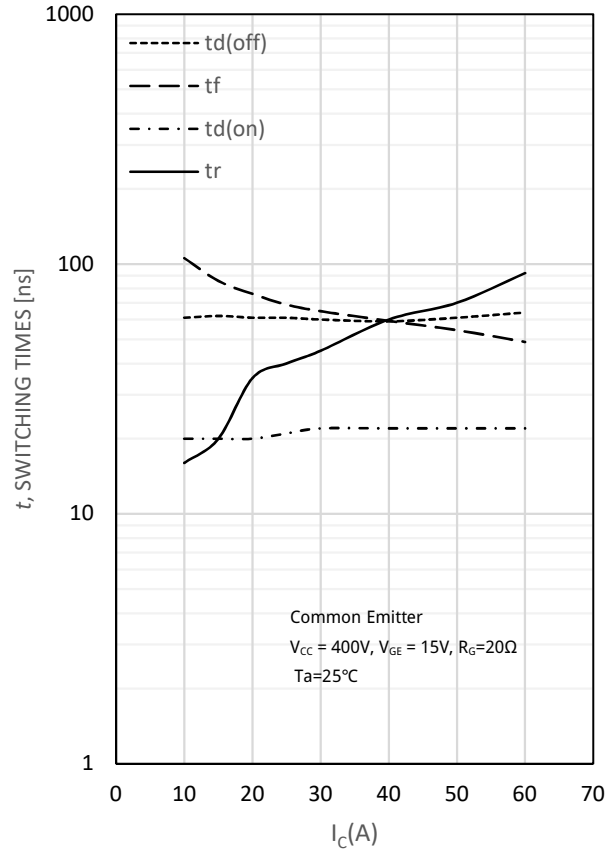

Fig. 9 Switching loss vs. gate resistor

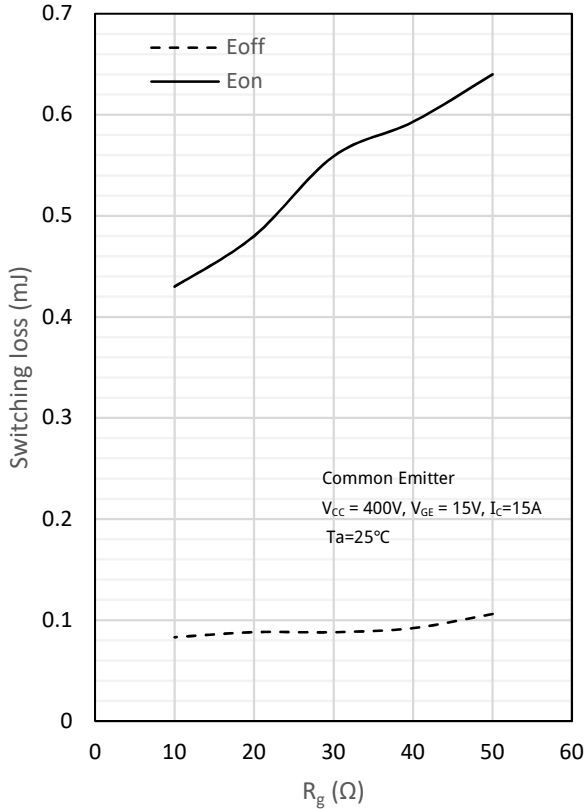

Fig. 10 Switching loss vs. collector current

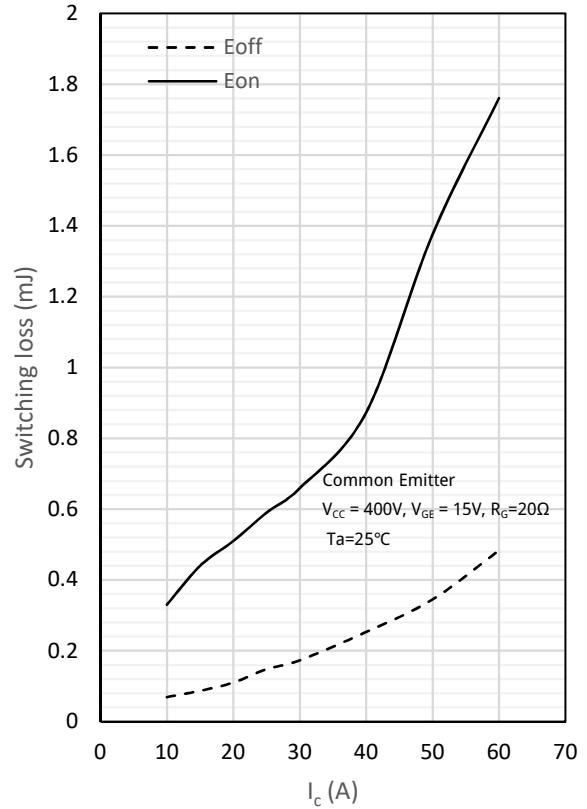

Fig. 11 Gate charge characteristics

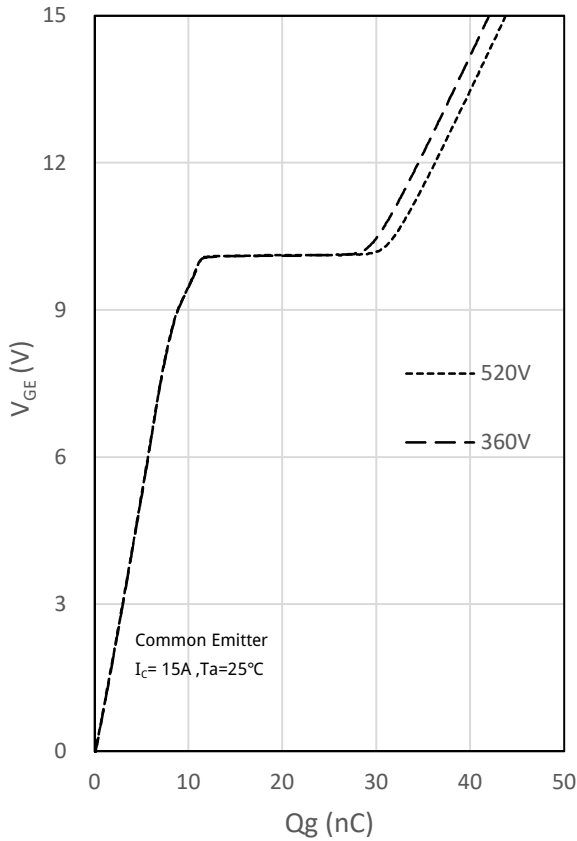
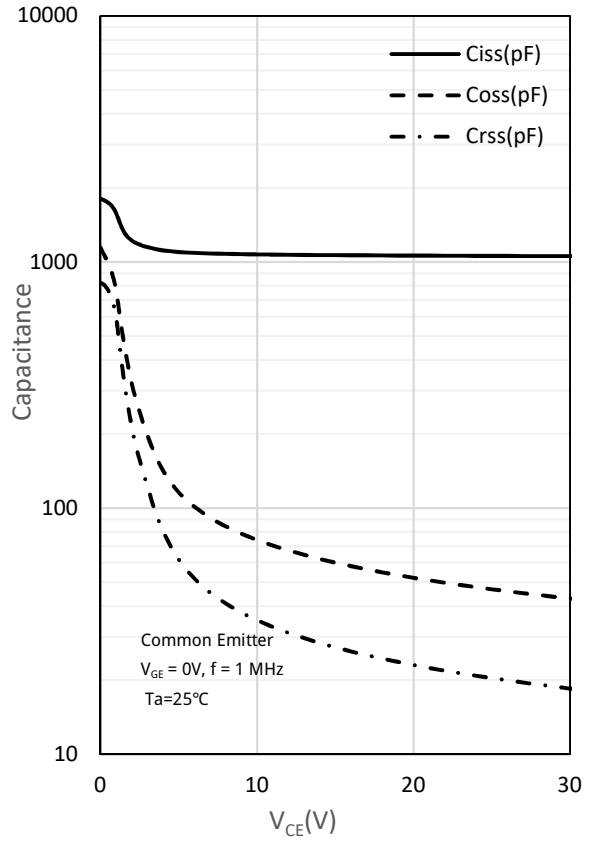
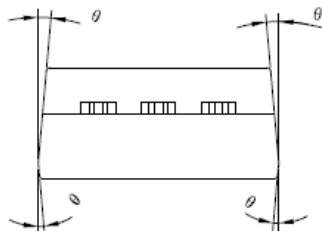
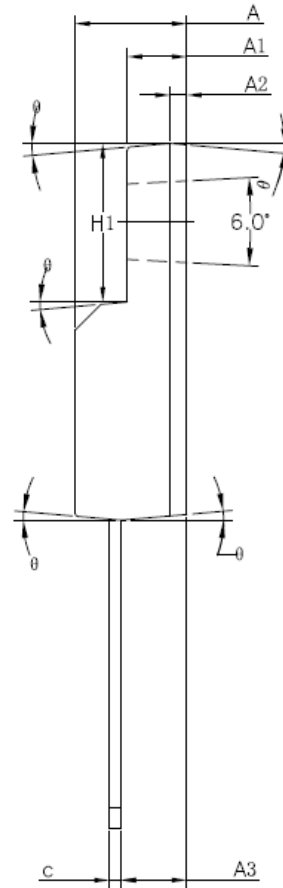
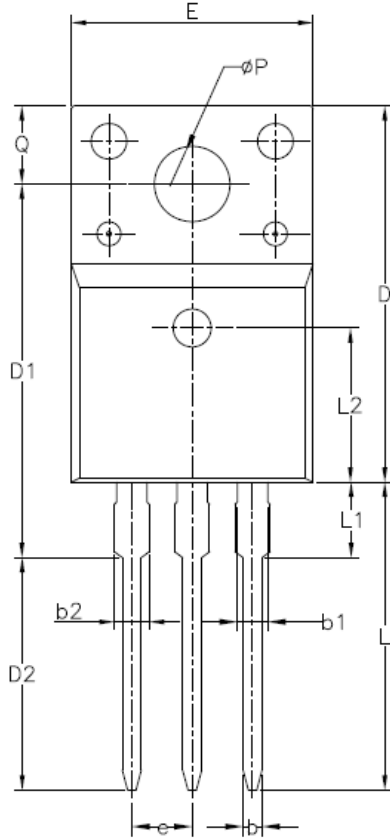

Fig. 12 Capacitance characteristics



TO-220F package information



SYMBOL	MIN	NOM	MAX
A	4.50	4.70	4.83
A1	2.34	2.54	2.74
A2	0.70 REF		
A3	2.56	2.76	2.93
b	0.70	-	0.90
b1	1.18	-	1.38
b2	-	-	1.47
c	0.45	0.50	0.60
D	15.67	15.87	16.07
D1	15.55	15.75	15.95
D2	9.60	9.80	10.0
E	9.96	10.16	10.36
e	2.54BSC		
H1	6.48	6.68	6.88
L	12.68	12.98	13.28
L1	-	-	3.50
L2	6.50REF		
øP	3.08	3.18	3.28
Q	3.20	-	3.40
θ 1	1°	3°	5°

TO-220 package information

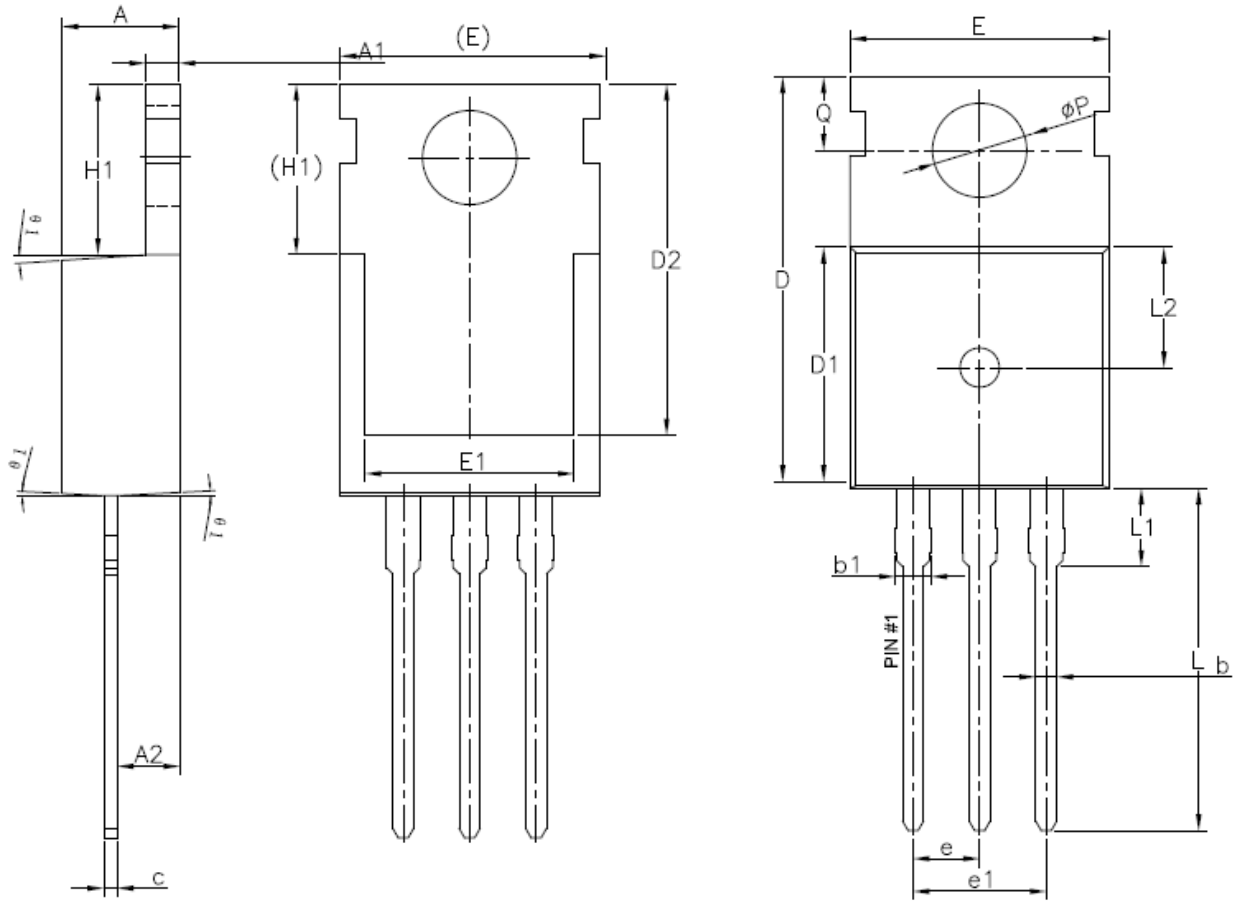

SYMBOL	MIN	NOM	MAX
A	4.40	4.50	4.60
A1	1.27	1.30	1.33
A2	2.30	2.40	2.50
b	0.70	—	0.90
b1	1.27	—	1.40
c	0.45	0.50	0.60
D	15.30	15.70	16.10
D1	9.10	9.20	9.30
D2	13.10	—	13.70
E	9.70	9.90	10.20
E1	7.80	8.00	8.20
e	2.49	2.54	2.59
e1	5.03	5.08	5.12
H1	6.30	6.50	6.70
L	12.78	13.08	13.38
L1	3.30	—	3.50
L2	4.50	4.60	4.70
φP	3.55	3.60	3.65
Q	2.73	—	2.87
θ 1	1°	3°	5°

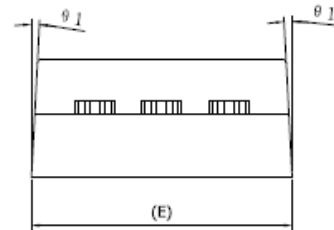

TO-263 package information

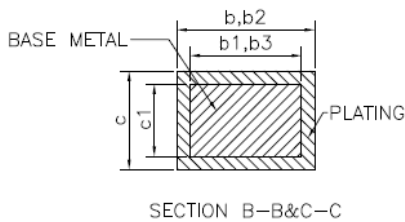
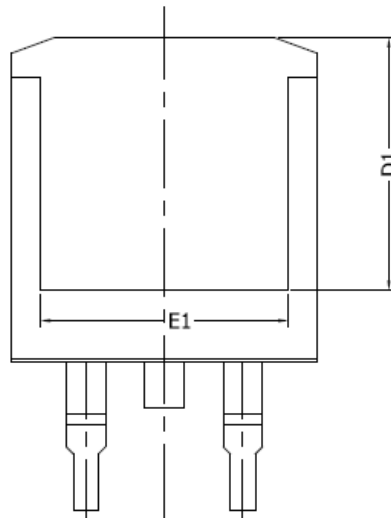
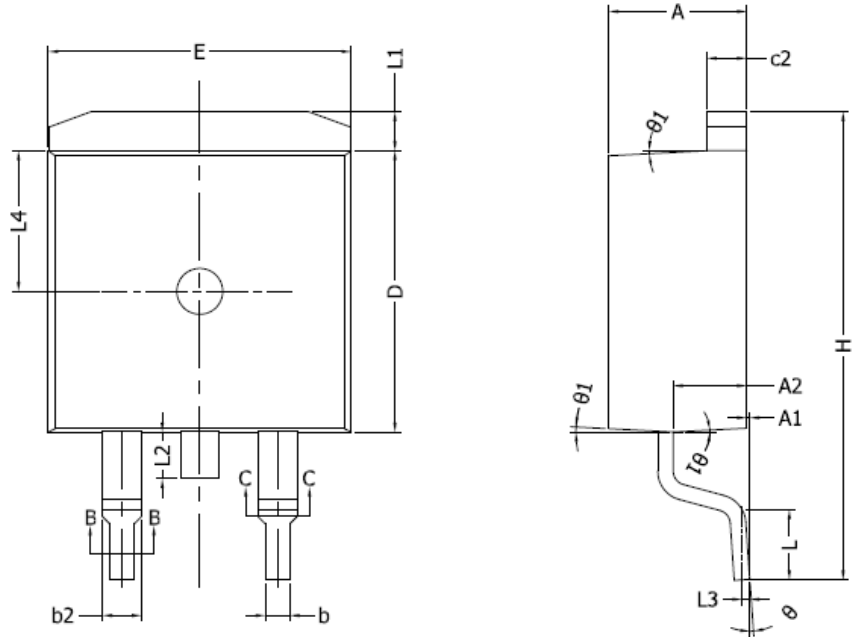

COMMON DIMENSIONS
(UNITS OF MEASURE =MILLIMETER)

SYMBOL	MIN	NOM	MAX
A	4.40	4.50	4.60
A1	0	0.10	0.25
A2	2.20	2.40	2.60
b	0.76	—	0.89
b1	0.75	0.80	0.85
b2	1.23	—	1.37
b3	1.22	1.27	1.32
c	0.47	—	0.60
c1	0.46	0.51	0.56
c2	1.25	1.30	1.35
D	9.10	9.20	9.30
D1	8.00	—	—
E	9.80	9.90	10.00
E1	7.80	—	—
e	2.54 BSC		
H	14.90	15.30	15.70
L	2.00	2.30	2.60
L1	1.17	1.27	1.40
L2	—	—	1.75
L3	0.25BSC		
L4	4.60 REF		
θ	0°	—	8°
θ1	1°	3°	5°