

REVISION RECORD				
REV	ECN	DESCRIPTION	DRFT	DATE

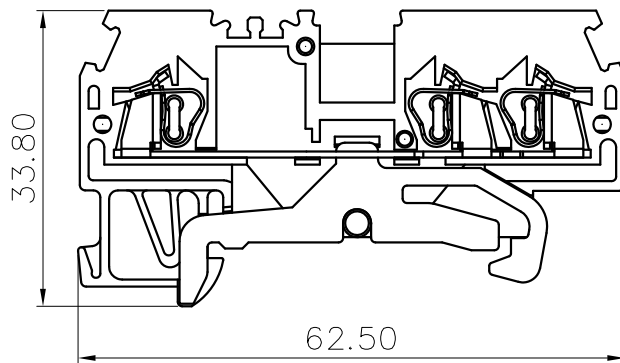
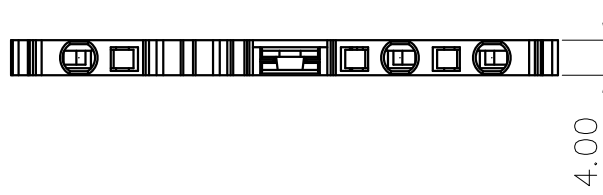
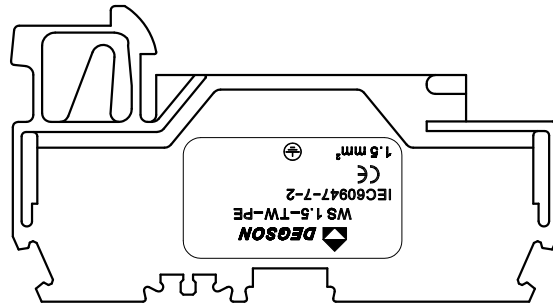

NOTES1:

UL Standard

1.Wire range : 28~16AWG

IEC Standard

1.

Pollution degree	3
Overvoltage category	III
Rate impulse voltage(KV)	8.0KV
Rate voltage(V)	/ V
Rate current(A)	/ A

2.Wire range : 0.2~1.5mm<sup>2</sup>

NOTES2:

1.Dimension shall be interpreted per ASME Y14.5-2009

2.Pitch : 4.0mm, Poles : 01P

3.Stripping length : 9~10mm

4.Operating temperature: -40°C~+105°C

5.Undimensioned tolerances:

Pitch range in mm		Nominal dimension range in mm				—	∩	□
TO	Over TO	Over TO	TO	Over TO	Over TO	Over TO	0.1/10	
6	6 TO 10	10 TO 24	TO 30	Over 30 TO 60	Over 60 TO 100	Over 100 TO 150	<	
	±0.15	±0.20	±0.30	±0.30	±0.50	±0.70	±1.00	±1.30
							±2'	

6.RoHS Compliance

WS1.5-TW-PE - 01P - 1C - 00A (H)  
 (Series No.) (Poles) (Single Pitch) (Color):(Yellow-Green)  
 (RoHS)  
 00A-(Standard)

DETACHED LISTS	PART NO.:	宁波高松电子有限公司 NINGBO DEGSON ELECTRICAL CO., LTD			
	APPD:	NAME: WS1.5-TW-PE-01P-1C-00A(H)			
	CHKD:	TITLE: CUSTOMER DRAWING			
	DRFT:	DRAWING NO.:		REV	DO
THIRD ANGLE PROJECTION		MM (INCH)	DO NOT SCALE DRAWING	SHEET 1/1	SCALE 1:1