

HIGH TORQUE HYBRID STEPPING MOTOR SPECIFICATIONS

General specifications		Electrical specifications	
Step Angle (°)	1.2	Rated Voltage (V)	6.24
Temperature Rise (°C)	80 Max (rated current, 2 phase on)	Rated Current (A)	5.2
Ambient Temperature (°C)	-20 ~ +50	Resistance Per Phase (± 10% Ω)	1.2 (25°C)
Number of Phase	3	Inductance Per Phase (± 20% mH)	5.2
Insulation Resistance (MΩ)	100 Min (500VDC)	Holding Torque (N.m)	4.52
Insulation Class	Class B	Weight (Kg)	3.1
Max.radial force (N)	220 (20mm from the flange)		
Max.axial force (N)	60		

● Wiring Diagram :

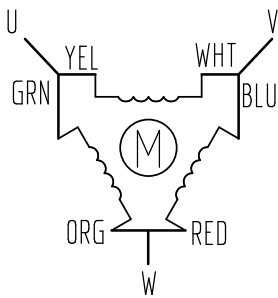

● Pull out torque curve :

VOLTAGE: 220VAC, CONSTANT CURRENT:5.2A,MS-3H110M HALF STEP

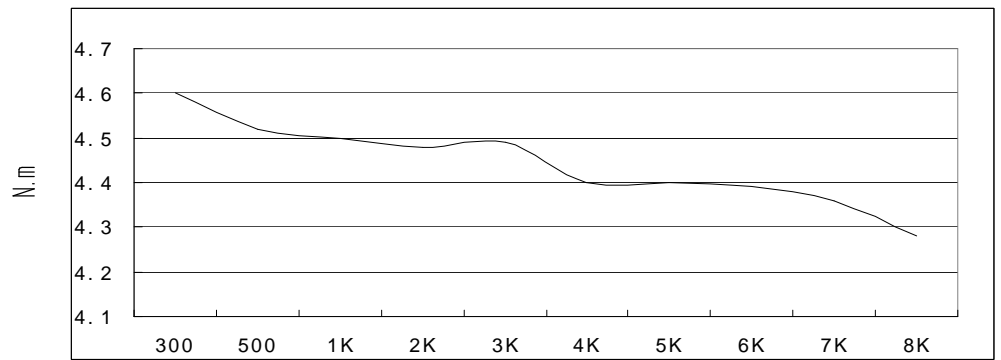

● Dimensions:

(unit=mm)

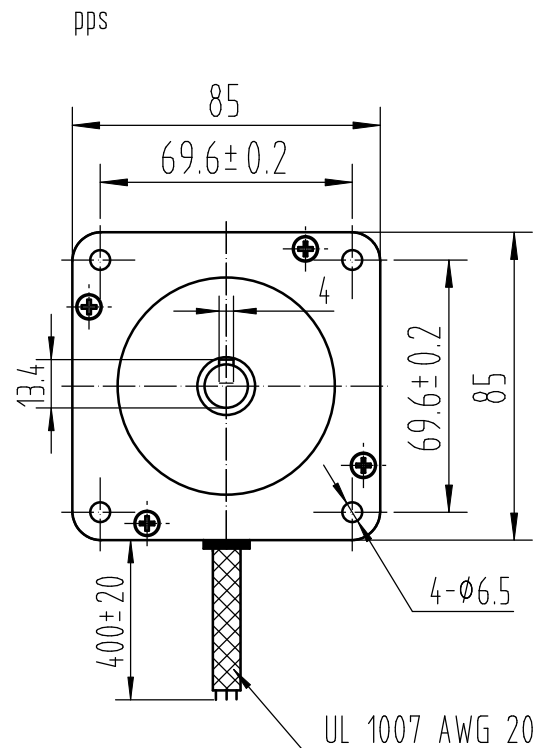
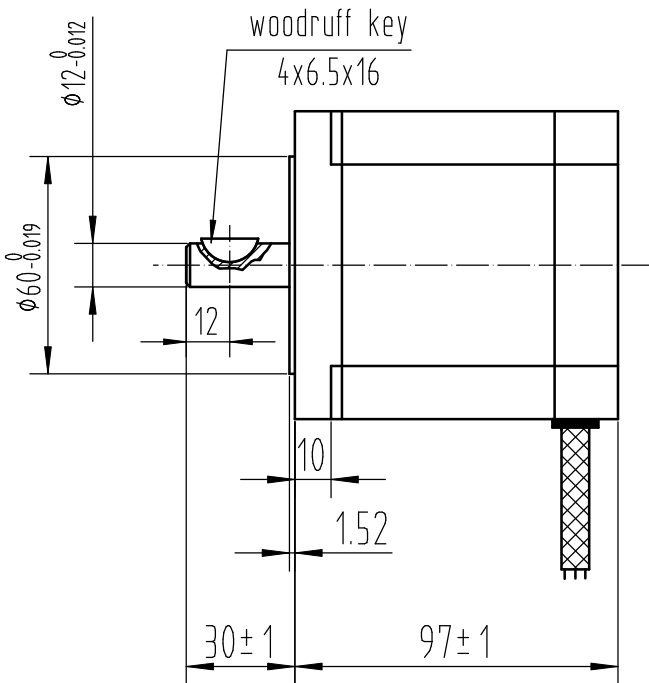

					SY853P97-5206A	TECHNICAL CONDITIONS
REV	REVISIONS	DESCRIPTION	BY	DATE	CHANGZHOU SONGYANG MACHINERY & ELECTRONICS NEW TECHNIC INSTITUTE	120097002
DRAW	Cheng Feng	2010/08/29				
CHECK						
APPROVE						

This document was created with Win2PDF available at <http://www.daneprairie.com>.
The unregistered version of Win2PDF is for evaluation or non-commercial use only.