

# HIGH TORQUE HYBRID STEPPING MOTOR SPECIFICATIONS

General specifications		Electrical specifications	
Step Angle (°)	0.9	Rated Voltage (V)	4
Temperature Rise (°C)	80 Max (rated current, 2 phase on)	Rated Current (A)	0.95
Ambient Temperature (°C)	-20 ~ +50	Resistance Per Phase (± 10% Ω)	4.2
Number of Phase	2	Inductance Per Phase (± 20% mH)	4
Insulation Resistance (MΩ)	100 Min (500VDC)	Holding Torque (N.cm)	15.8
Insulation Class	Class B	Detent Torque (N.cm)	200
Max.radial force (N)	28 (20mm from the flange)	Rotor Torque (N.cm <sup>2</sup> )	68
Max.axial force (N)	10		

● Wiring Diagram :

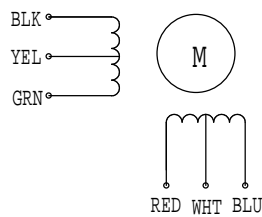

● Pull out torque curve :

VOLTAGE: 24VDC, CONSTANT CURRENT:0.9A,HALF STEP

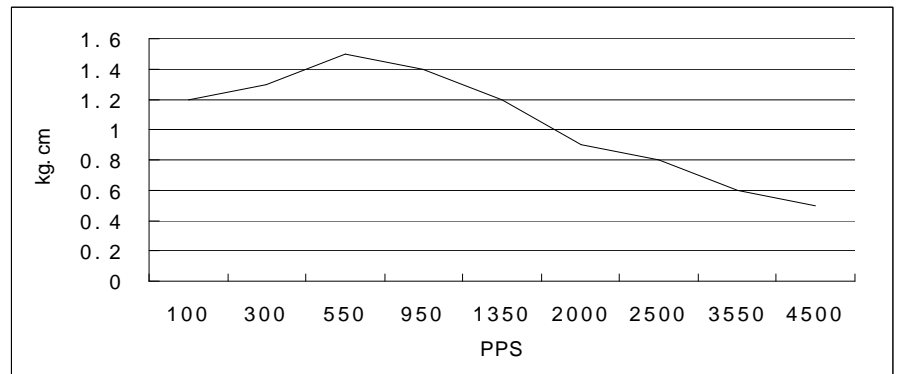

● Dimensions:

(unit=mm)

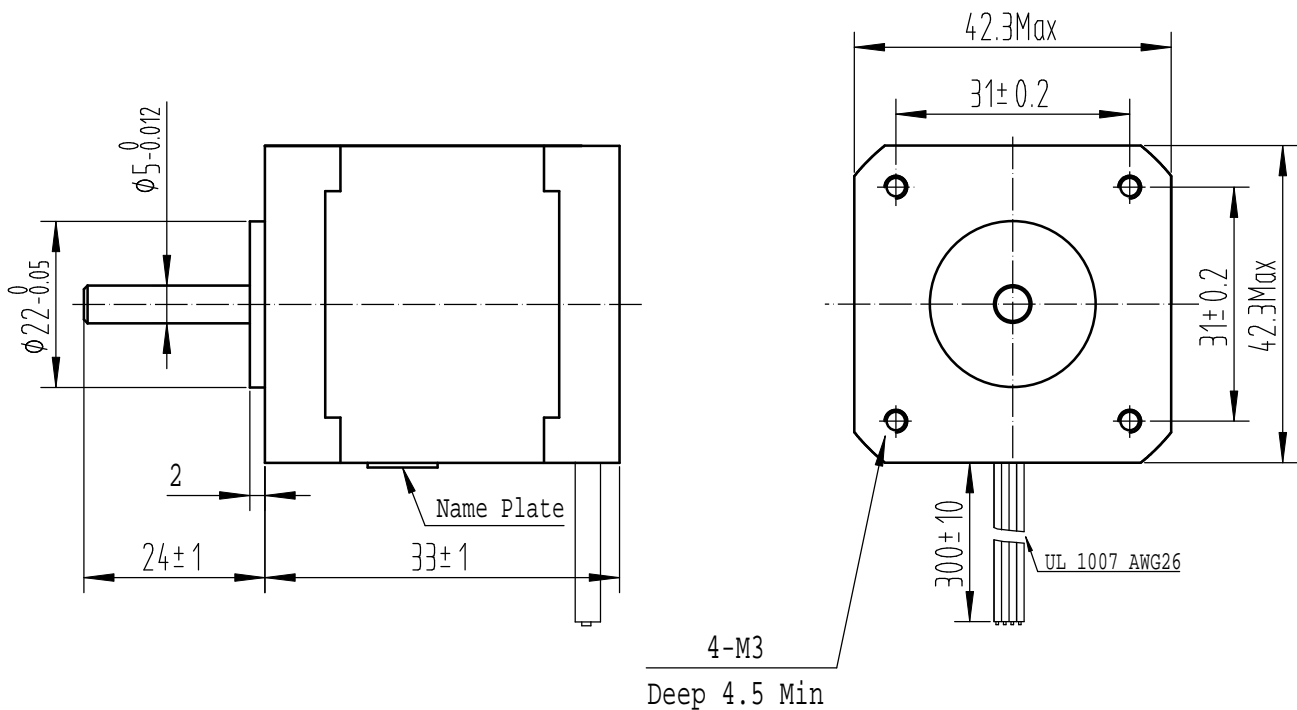

REV	REVISIONS	DESCRIPTION	BY	DATE	SY42STH33-0956MA	TECHNICAL CONDITIONS
DRAW	孔祥振	2012.02.20			CHANGZHOU SONGYANG MACHINERY & ELECTRONICS NEW TECHNIC INSTITUTE	050033000
CHECK						
APPROVE						

This document was created with Win2PDF available at <http://www.daneprairie.com>.  
The unregistered version of Win2PDF is for evaluation or non-commercial use only.