



8-Bit Constant Current LED Sink Driver with Gain Control

Features

- Compatible with MBI5168 in package and electrical characteristics
- Exploit **Share-I-O™** technique to provide two operation modes: Normal Mode with the same functionality as MB5168, Current Adjust Mode to program output current gain
- 8 constant-current output channels
- Output current adjustable through an external resistor
- Constant output current range: 5 -120 mA
- Excellent output current accuracy, between channels < ±3% (max.), and between ICs < ±6% (max.).
- Constant output current invariant to load voltage change
- Fast response of output current, \overline{OE} (min.): 200 ns @ $I_{out} < 60mA$
 \overline{OE} (min.): 400 ns @ $I_{out} = 60\sim 100mA$
- 25MHz clock frequency
- Schmitt trigger input
- 3.3V~ 5V supply voltage
- 256-step run-time programmable output current gain suitable for white balance application
- Optional for "Pb-free & Green" Package

Dual In-Line Package

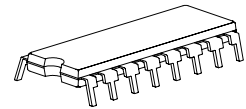

P-DIP16-300-2.54 Weight : 1.02g

Small Outline Package

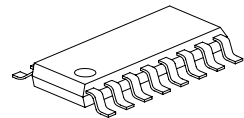

SOP16-150-1.27 Weight : 0.13g

Wide-body SOP

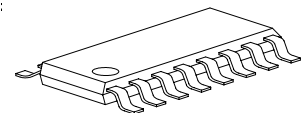

SOP16-300-1.27 Weight : 0.37g

Shrink SOP

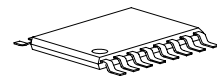

SSOP16-150-0.64 Weight : 0.07g

Current Accuracy		Conditions
Between Channels	Between ICs	
< ±3%	< ±6%	$I_{OUT} = 10 \sim 100 \text{ mA}$, $V_{DS} = 0.8V, V_{DD} = 5.0V$

Product Description

MBI5170 succeeds MBI5168 and also exploits **PrecisionDrive™** technology to enhance its output characteristics. Furthermore, MBI5170 uses the idea of **Share-I-O™** technique to make MBI5170 backward compatible with MBI5168 in both package and electrical characteristics and extend its functionality for run-time LED current gain control in LED display systems.

MBI5170 contains an 8-bit Shift Register and an 8-bit Output Latch, which convert serial input data into parallel output format. At MBI5170 output stages, eight regulated current ports are designed to provide uniform and constant current sinks with small skew between ports for driving LED's with a wide range of forward voltage (Vf) variations. Users may adjust the output current from 5 mA to 120 mA with an external resistor R_{ext} , which gives users flexibility in controlling the light intensity of LED's. MBI5170 guarantees to endure maximum 17V at the output ports. Besides, the high clock frequency up to 25 MHz also satisfies the system requirements of high volume data transmission.

By means of the **Share-I-O™** technique, MBI5170 adds new functionality on the pins LE and \overline{OE} of MBI5168 to provide an additional function, Current Gain Control, without any extra pins. Thus, MBI5170 could be a drop-in replacement of MBI5168. The printed circuit board originally designed for MBI5168 may be also applied to MBI5170. In MBI5170 there are two operation modes and three phases: Normal Mode phase, Mode Switching transition phase, and Current Adjust Mode phase. The signal on the multi-function pin \overline{OE}/SW would be monitored. Once a one-clock-wide short pulse appears on the pin \overline{OE}/SW , MBI5170 would enter the Mode Switching phase. At this moment, the voltage level on the pin LE/MOD/CA is used for determining the next mode to which MBI5170 is going to switch.

In the Normal Mode phase, MBI5170 has similar functionality to MBI5168. The serial data could be transferred into MBI5170 via the pin SDI, shifted in the Shift Register, and go out via the pin SDO. The LE/MOD/CA can latch the serial data in the Shift Register to the Output Latch. \overline{OE}/SW would enable the output drivers to sink current.

On the other hand, the Current Adjust Mode phase allows users to adjust the output current level by setting a run-time programmable Configuration Code. The code is sent into MBI5170 via the pin SDI. The positive pulse of LE/MOD/CA would latch the code in the Shift Register into a built-in 8-bit Configuration Latch, instead of the Output Latch. The code would affect the voltage at the terminal R-EXT and control the output current regulator. The output current could be adjusted finely by a current gain ranging from (1/12) to (127/128) in 256 steps. Hence, the current skew between IC's can be compensated within less than 1% and this feature is suitable for white balancing in LED color display panels.

Pin Assignment

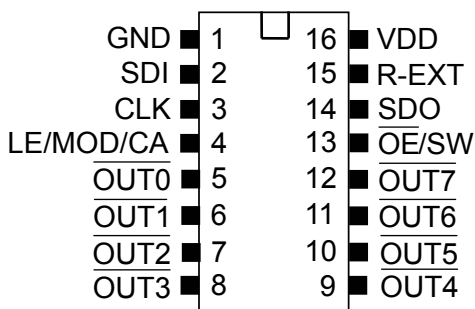

Terminal Description

Pin No.	Pin Name	Function
1	GND	Ground terminal for control logic and current sinks
2	SDI	Serial-data input to the Shift Register
3	CLK	Clock input terminal for data shift on rising edge
4	LE/MOD/CA	<p>Output channel data strobe input terminal: in the Normal Mode phase, serial data in the Shift Register is transferred to the respective Output Latch when LE/MOD/CA is high; the data is latched inside the Output Latch when LE/MOD/CA goes low. If the data in the Output Latch is “1” (High), the respective output channel will be enabled after \overline{OE}/SW is pulled down to low.</p> <p>Mode selection input terminal: in the Mode Switching phase, LE/MOD/CA couldn't strobe serial data but its level is used for determining the next mode to which MBI5170 is going to switch. When LE/MOD/CA is high, the next mode is the Current Adjust Mode; when low, the next mode is the Normal Mode.</p> <p>Configuration data strobe input terminal: in the Current Adjust Mode phase, serial data is latched into the Configuration Latch, instead of the Output Latch in the Normal Mode. The serial data here is regarded as the Configuration Code, which affect the output current level of all channels. (See Operation Principle)</p>
5-12	$\overline{OUT0} \sim \overline{OUT7}$	Constant current output terminals
13	\overline{OE}/SW	<p>Output enable terminal: no matter in what phase MBI5170 operates, the signal \overline{OE}/SW can always enable output drivers to sink current. When its level is (active) low, the output drivers are enabled; when high, all output drivers are turned OFF (blanked).</p> <p>Mode switching trigger terminal: a one-clock-wide short signal pulse of \overline{OE}/SW could put MBI5170 into the Mode Switching phase. (See Operation Principle)</p>
14	SDO	Serial-data output to the following SDI of next driver IC
15	R-EXT	Input terminal used to connect an external resistor for setting up all output current
16	VDD	Supply voltage terminal

In MBI5170, the relationship between the functions of pin 4 and 13 and the operation phases is listed below:

Pin No.	Pin Name	Function	Normal Mode	Mode Switching	Current Adjust Mode
4	LE/MOD/CA	LE: latching serial data into the Output Latch	Yes	No	No
		MOD: mode selection	No	Yes	No
		CA: latching serial data into the Configuration Latch	No	No	Yes
13	\overline{OE}/SW	\overline{OE} : enabling the current output drivers	Yes	Yes	Yes
		SW: entering the Mode Switching phase	Yes	Yes	Yes

Block Diagram

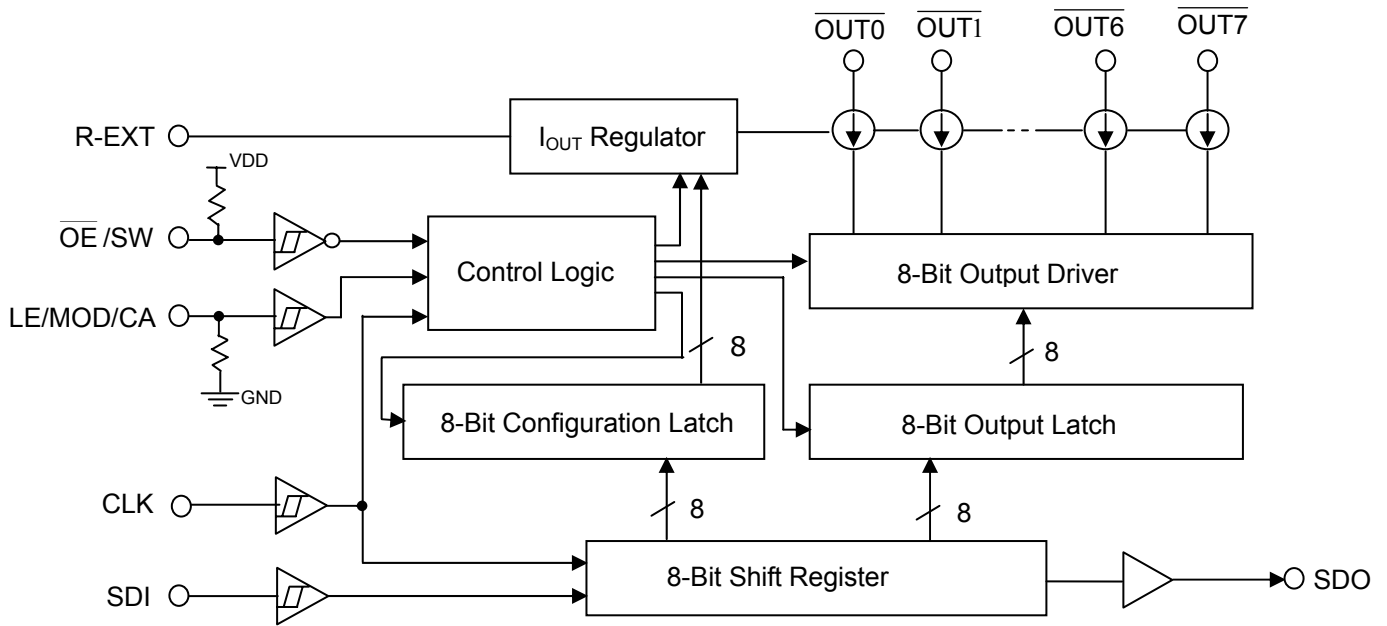

Equivalent Circuits of Inputs and Outputs

\overline{OE}/SW Terminal

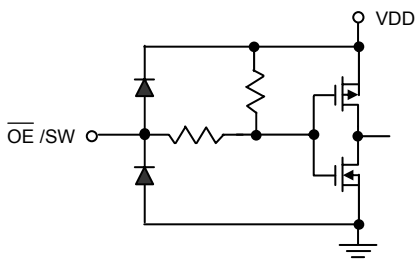

LE/MOD/CA Terminal

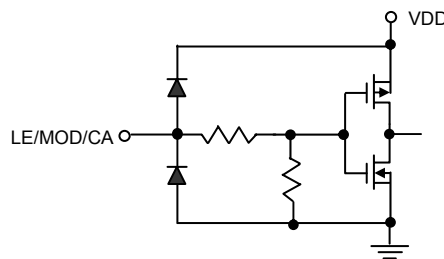

CLK, SDI Terminal

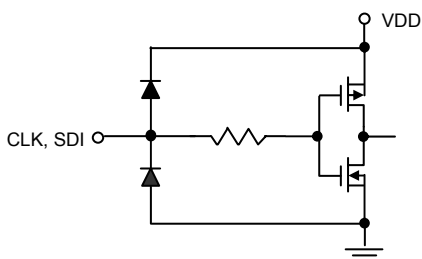

SDO Terminal

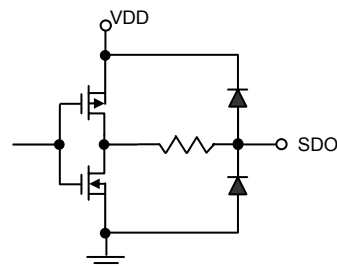

Timing Diagram

Normal Mode

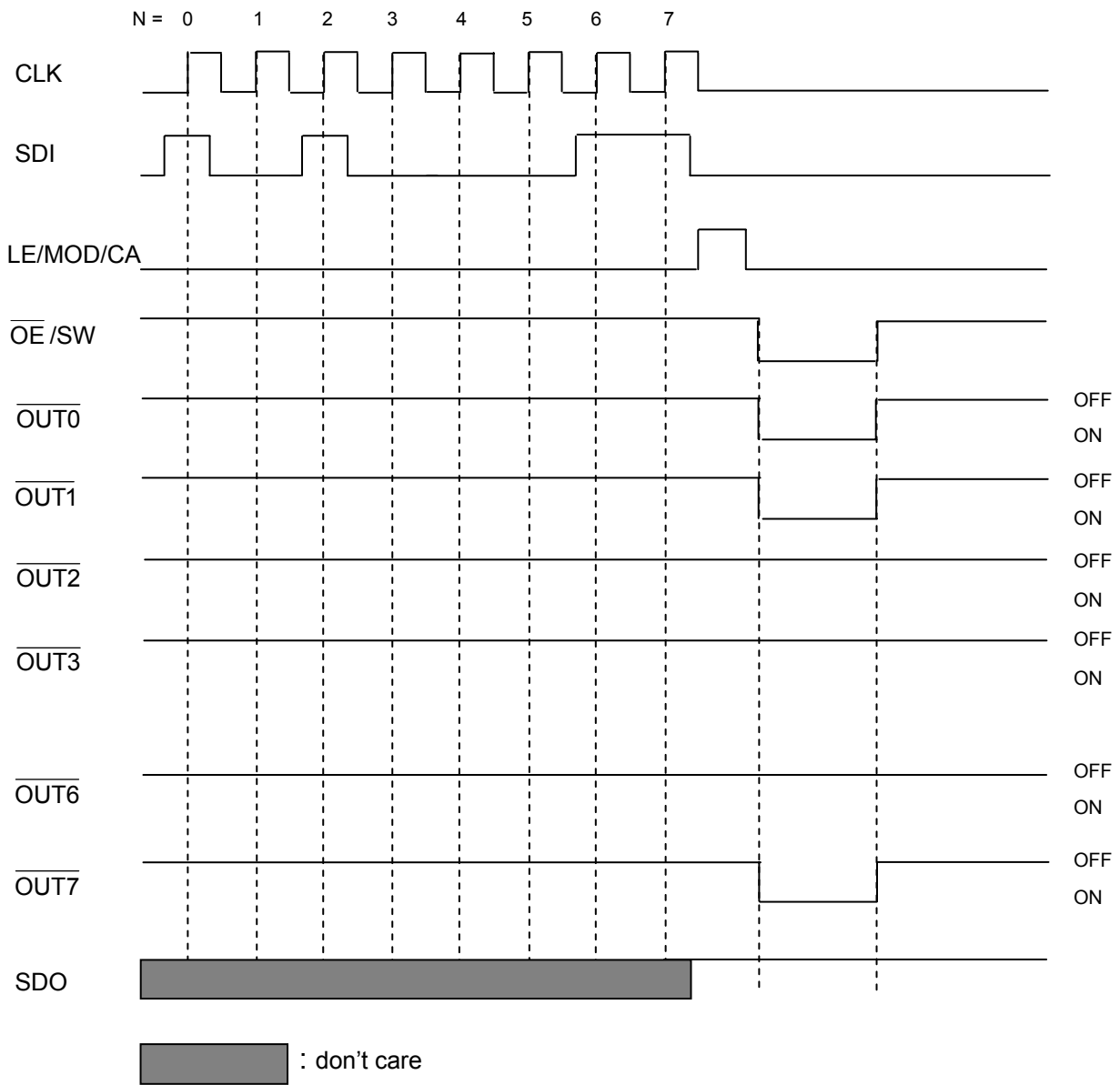

Truth Table (In Normal Mode)

CLK	LE/MOD/CA	OE/SW	SDI	OUT0 ... OUT5 ... OUT7	SDO
	H	L	D _N	$\overline{D_n} \dots \overline{D_{n-5}} \dots \overline{D_{n-7}}$	D _{N-7}
	L	L	D _{N+1}	No Change	D _{N-6}
	H	L	D _{N+2}	$\overline{D_{n+2}} \dots \overline{D_{n-3}} \dots \overline{D_{n-5}}$	D _{N-5}
	X	L	D _{N+3}	$\overline{D_{n+2}} \dots \overline{D_{n-3}} \dots \overline{D_{n-5}}$	D _{N-5}
	X	H	D _{N+3}	Off	D _{N-5}

MBI5170 8-Bit Constant Current LED Sink Driver with Gain Control

Switching to Current Adjust Mode

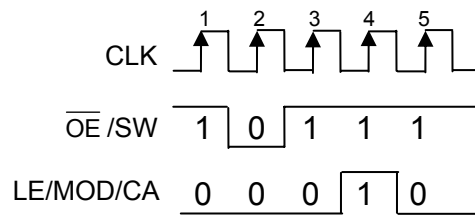

The above shows an example of the signal sequence that can set the next operation mode of MBI5170 to be the Current Adjust Mode. The LE/MOD/CA active pulse here would not latch any serial data.

Writing Configuration Code (In Current Adjust Mode)

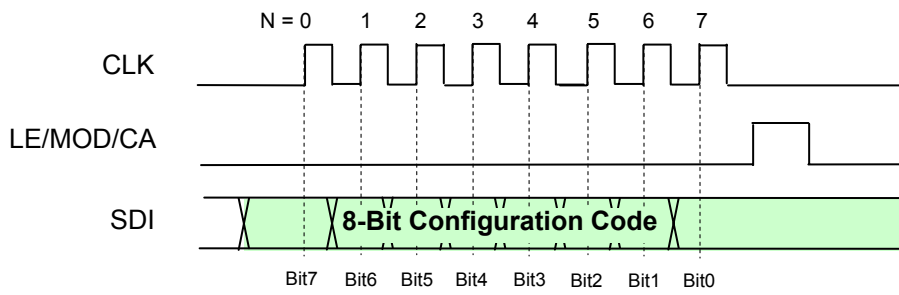

In the Current Adjust Mode, by sending the positive pulse of LE/MOD/CA, the content of the Shift Register with a Configuration Code will be written to the 8-bit Configuration Latch.

Switching to Normal Mode

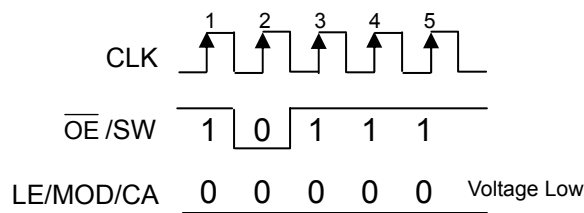

The above signal sequence example can make MBI5170 resume to the Normal Mode.

Note:

If users want to know the whole process, that is how to enter the Current Adjust Mode, write the Configuration Code, and resume to the Normal Mode, please refer to the section **Operation Principle**.

Maximum Ratings

Characteristics			Symbol	Rating		Unit
Supply Voltage			V_{DD}	0 ~ 7.0		V
Input Voltage			V_{IN}	-0.4 ~ $V_{DD} + 0.4$		V
Output Current			I_{OUT}	+120		mA
Output Voltage			V_{DS}	-0.5 ~ +20		V
Clock Frequency			F_{CLK}	25		MHz
GND Terminal Current			I_{GND}	1000		mA
Power Dissipation (On PCB, $T_a=25^\circ\text{C}$)	CN	GN	P_D	1.55	1.66	W
	CD	GD		1.17	1.43	
	CDW	GDW		1.62	1.46	
	CP	GP		1.05	1.25	
Thermal Resistance (On PCB, $T_a=25^\circ\text{C}$)	CN	GN	$R_{th(j-a)}$	64.35	60.20	$^\circ\text{C/W}$
	CD	GD		85.82	70.14	
	CDW	GDW		61.63	68.67	
	CP	GP		94.91	80.00	
Operating Temperature			T_{opr}	-40 ~ +85		$^\circ\text{C}$
Storage Temperature			T_{stg}	-55 ~ +150		$^\circ\text{C}$

Recommended Operating Conditions

Characteristics	Symbol	Condition	Min.	Typ.	Max.	Unit
Supply Voltage	V_{DD}	-	4.5	5.0	5.5	V
Output Voltage	V_{DS}	$\overline{OUT0} \sim \overline{OUT7}$	-	-	17.0	V
Output Current	I_{OUT}	$\overline{OUT0} \sim \overline{OUT7}$, CM*=1, $V_{DD} = 5V$	10	-	120	mA
	I_{OUT}	$\overline{OUT0} \sim \overline{OUT7}$, CM*=0, $V_{DD} = 5V$	5	-	40	mA
	I_{OH}	SDO	-	-	-1.0	mA
	I_{OL}	SDO	-	-	1.0	mA
Input Voltage	V_{IH}	CLK, \overline{OE}/SW , LE/MOD/CA, and SDI	$0.7V_{DD}$	-	$V_{DD}+0.3$	V
	V_{IL}	CLK, \overline{OE}/SW , LE/MOD/CA, and SDI	-0.3	-	$0.3V_{DD}$	V
CLK Pulse Width	$t_{w(CLK)}$	-	20	-	-	ns
Setup Time for SDI	$t_{su(D)}$		5	-	-	ns
Hold Time for SDI	$t_h(D)$		10	-	-	ns
LE/MOD/CA Pulse Width	$t_{w(L)}$		20	-	-	ns
Setup Time for LE/MOD/CA	$t_{su(L)}$	For data strobe in both Normal Mode and Current Adjust Mode	5	-	-	ns
Hold Time for LE/MOD/CA	$t_h(L)$		10	-	-	ns
Setup Time for LE/MOD/CA	$t_{su(MOD)}$	In Mode Switching	5	-	-	ns
Hold Time for LE/MOD/CA	$t_h(MOD)$		10	-	-	ns
\overline{OE}/SW Pulse Width	$t_{w(SW)}$	To trigger Mode Switching	20	-	-	ns
	$t_{w(OE)}$	$I_{out} < 60mA$	200	-	-	ns
	$t_{w(OE)}$	$I_{out} = 60 \sim 100mA$	400	-	-	ns
Setup Time for \overline{OE}/SW	$t_{su(SW)}$	To trigger Mode Switching	5	-	-	ns
Hold Time for \overline{OE}/SW	$t_h(SW)$		10	-	-	ns
Clock Frequency	F_{CLK}	Cascade Operation ($V_{DD} = 5.0V$)	-	-	25.0	MHz

* CM is one bit in configuration code and called as "Current Multiplier." It would affect the ratio of I_{OUT} to I_{ext} . The detail information could be found in the section **Operation Principle**.

Electrical Characteristics (V_{DD} = 5.0V)

Characteristics		Symbol	Condition	Min.	Typ.	Max.	Unit	
Supply Voltage		V _{DD}	-	4.5	5.0	5.5	V	
Output Voltage		V _{DS}	$\overline{\text{OUT0}} \sim \overline{\text{OUT7}}$	-	-	17.0	V	
Output Current		I _{OUT}	$\overline{\text{OUT0}} \sim \overline{\text{OUT7}}$, CM = 1	10	-	120	mA	
		I _{OUT}	$\overline{\text{OUT0}} \sim \overline{\text{OUT7}}$, CM = 0	5	-	40	mA	
		I _{OH}	SDO	-	-	-1.0	mA	
		I _{OL}	SDO	-	-	1.0	mA	
Input Voltage	“H” level	V _{IH}	Ta = -40~85°C	0.7V _{DD}	-	V _{DD}	V	
	“L” level	V _{IL}	Ta = -40~85°C	GND	-	0.3V _{DD}	V	
Output Leakage Current			V _{DS} =17.0V and channel off	-	-	0.5	μA	
Output Voltage	SDO	V _{OL}	I _{OL} =+1.0mA	-	-	0.4	V	
		V _{OH}	I _{OH} =-1.0mA	4.6	-	-	V	
Output Current 1		I _{OUT1}	V _{DS} = 0.5V; R _{ext} = 744Ω; VG** = 0.992; CM = 1	-	25.0	-	mA	
Current Skew (between channels)		dI _{OUT1}	I _{OUT} = 25mA V _{DS} ≥ 0.5V	R _{ext} =744 Ω	-	±1	±3	%
Output Current 2		I _{OUT2}	V _{DS} = 0.6V; R _{ext} = 372Ω; VG** = 0.992; CM = 1	-	50.0	-	mA	
Current Skew (between channels)		dI _{OUT2}	I _{OUT} = 50mA V _{DS} ≥ 0.6V	R _{ext} =372 Ω	-	±1	±3	%
Output Current 3		I _{OUT3}	V _{DS} = 0.8V; R _{ext} = 186Ω; VG** = 0.992; CM = 1	-	100	-	mA	
Current Skew (between channels)		dI _{OUT3}	I _{OUT} = 100mA V _{DS} ≥ 0.8V	R _{ext} =186 Ω	-	±1	±3	%
Output Current vs. Output Voltage Regulation		%/dV _{DS}	V _{DS} within 1.0V and 3.0V	-	±0.1	-	% / V	
Output Current vs. Supply Voltage Regulation		%/dV _{DD}	V _{DD} within 4.5V and 5.5V	-	+0.5	-	% / V	
Pull-up Resistor		R _{IN} (up)	$\overline{\text{OE}}/\text{SW}$	250	500	800	KΩ	
Pull-down Resistor		R _{IN} (down)	LE/MOD/CA	250	500	800	KΩ	
Supply Current	“OFF”	I _{DD} (off) 0	R _{ext} =Open, $\overline{\text{OUT0}} \sim \overline{\text{OUT7}}$ =Off; CM = 1, VG = 0.992	-	2.85	3.65	mA	
		I _{DD} (off) 1	R _{ext} =744 Ω, $\overline{\text{OUT0}} \sim \overline{\text{OUT7}}$ =Off; CM = 1, VG = 0.992	-	5.9	7.9		
		I _{DD} (off) 2	R _{ext} =372 Ω, $\overline{\text{OUT0}} \sim \overline{\text{OUT7}}$ =Off; CM = 1, VG = 0.992	-	8.7	10.7		
		I _{DD} (off) 3	R _{ext} =186 Ω, $\overline{\text{OUT0}} \sim \overline{\text{OUT7}}$ =Off; CM = 1, VG = 0.992	-	14.4	16.4		
	“ON”	I _{DD} (on) 1	R _{ext} =744 Ω, $\overline{\text{OUT0}} \sim \overline{\text{OUT7}}$ =On; CM = 1, VG = 0.992	-	5.8	7.8		
		I _{DD} (on) 2	R _{ext} =372 Ω, $\overline{\text{OUT0}} \sim \overline{\text{OUT7}}$ =On; CM = 1, VG = 0.992	-	8.7	10.7		
I _{DD} (on) 3		R _{ext} =186 Ω, $\overline{\text{OUT0}} \sim \overline{\text{OUT7}}$ =On; CM = 1, VG = 0.992	-	13.5	15.5			

** In the above table, VG is the programmable gain of the voltage at the terminal R-EXT. The detail description could be found in the section **Operation Principle**.

Electrical Characteristics (V_{DD} = 3.3V)

Characteristics		Symbol	Condition	Min.	Typ.	Max.	Unit	
Supply Voltage		V _{DD}	-	3.0	3.3	3.6	V	
Output Voltage		V _{DS}	$\overline{\text{OUT0}} \sim \overline{\text{OUT7}}$	-	-	17.0	V	
Output Current		I _{OUT}	$\overline{\text{OUT0}} \sim \overline{\text{OUT7}}$, CM=1,	10	-	120	mA	
		I _{OUT}	$\overline{\text{OUT0}} \sim \overline{\text{OUT7}}$, CM=0,	5	-	40	mA	
		I _{OH}	SDO	-	-	-1.0	mA	
		I _{OL}	SDO	-	-	1.0	mA	
Input Voltage	“H” level	V _{IH}	Ta = -40~85°C	0.7V _{DD}	-	V _{DD}	V	
	“L” level	V _{IL}	Ta = -40~85°C	GND	-	0.3V _{DD}	V	
Output Leakage Current			V _{DS} =17.0V and channel off	-	-	0.5	μA	
Output Voltage	SDO	V _{OL}	I _{OL} =+1.0mA	-	-	0.4	V	
		V _{OH}	I _{OH} =-1.0mA	2.9	-	-	V	
Output Current 1		I _{OUT1}	V _{DS} = 0.5V; R _{ext} = 744Ω; VG = 0.992; CM = 1	-	25.0	-	mA	
Current Skew (between channels)		dI _{OUT1}	I _{OUT} = 25mA V _{DS} ≥ 0.5V	R _{ext} =744 Ω	-	±1	±3	%
Output Current 2		I _{OUT2}	V _{DS} = 0.6V; R _{ext} = 372Ω; VG = 0.992; CM = 1	-	50.0	-	mA	
Current Skew (between channels)		dI _{OUT2}	I _{OUT} = 50mA V _{DS} ≥ 0.6V	R _{ext} =372 Ω	-	±1	±3	%
Output Current vs. Output Voltage Regulation		%/dV _{DS}	V _{DS} within 1.0V and 3.0V	-	±0.1	-	% / V	
Output Current vs. Supply Voltage Regulation		%/dV _{DD}	V _{DD} within 3.2V and 3.6V	-	±1	-	% / V	
Pull-up Resistor		R _{IN(up)}	$\overline{\text{OE}} / \text{SW}$	250	500	800	KΩ	
Pull-down Resistor		R _{IN(down)}	LE/MOD/CA	250	500	800	KΩ	
Supply Current	“OFF”	I _{DD(off) 0}	R _{ext} =Open, $\overline{\text{OUT0}} \sim \overline{\text{OUT7}}$ =Off; CM = 1, VG = 0.992	-	0.78	1.58	mA	
		I _{DD(off) 1}	R _{ext} =744 Ω, $\overline{\text{OUT0}} \sim \overline{\text{OUT7}}$ =Off; CM = 1, VG = 0.992	-	3.6	4.4		
		I _{DD(off) 2}	R _{ext} =372 Ω, $\overline{\text{OUT0}} \sim \overline{\text{OUT7}}$ =Off; CM = 1, VG = 0.992	-	6.5	7.3		
	“ON”	I _{DD(on) 1}	R _{ext} =744 Ω, $\overline{\text{OUT0}} \sim \overline{\text{OUT7}}$ =On; CM = 1, VG = 0.992	-	3.6	4.2		
		I _{DD(on) 2}	R _{ext} =372 Ω, $\overline{\text{OUT0}} \sim \overline{\text{OUT7}}$ =On; CM = 1, VG = 0.992	-	6.4	7.2		

Switching Characteristics (V_{DD} = 5.0V)

Characteristics		Symbol	Condition	Min.	Typ.	Max.	Unit
Propagation Delay Time ("L" to "H")	CLK - $\overline{\text{OUTn}}$	t_{pLH1}	Test Circuit for Switching Characteristics V _{DD} =5.0 V V _{DS} =0.8 V V _{IH} =V _{DD} V _{IL} =GND R _{ext} =372 Ω V _L =4.0 V R _L =64 Ω C _L =10 pF VG = 0.992 CM = 1	-	100	150	ns
	LE/MOD/CA - $\overline{\text{OUTn}}$	t_{pLH2}		-	100	150	ns
	$\overline{\text{OE}}$ / SW - $\overline{\text{OUTn}}$	t_{pLH3}		-	100	150	ns
	CLK - SDO	t_{pLH}		20	25	30	ns
Propagation Delay Time ("H" to "L")	CLK - $\overline{\text{OUTn}}$	t_{pHL1}		-	100	150	ns
	LE/MOD/CA - $\overline{\text{OUTn}}$	t_{pHL2}		-	100	150	ns
	$\overline{\text{OE}}$ / SW - $\overline{\text{OUTn}}$	t_{pHL3}		-	100	150	ns
	CLK - SDO	t_{pHL}		20	25	30	ns
Pulse Width	CLK	$t_{\text{w(CLK)}}$		20	-	-	ns
	LE/MOD/CA	$t_{\text{w(L)}}$		20	-	-	ns
	$\overline{\text{OE}}$ / SW (@I _{out} < 60mA)	$t_{\text{w(OE)}}$		200	-	-	ns
Hold Time for LE/MOD/CA		$t_{\text{h(L)}}$		10	-	-	ns
Setup Time for LE/MOD/CA		$t_{\text{su(L)}}$		5	-	-	ns
Maximum CLK Rise Time		t_{r}^{***}		-	-	500	ns
Maximum CLK Fall Time		t_{f}^{***}		-	-	500	ns
Output Rise Time of V _{out} (turn off)		t_{or}		-	120	150	ns
Output Fall Time of V _{out} (turn on)		t_{of}	-	200	250	ns	
Clock Frequency		F _{CLK}	Cascade Operation	-	-	25.0	MHz

*** If MBI5170 are connected in cascade and t_r or t_f is large, it may be critical to achieve the timing required for data transfer between two cascaded LED drivers MBI5170.

Switching Characteristics ($V_{DD} = 3.3V$)

Characteristics		Symbol	Condition	Min.	Typ.	Max.	Unit
Propagation Delay Time ("L" to "H")	CLK - \overline{OUTn}	t_{pLH1}	Test Circuit for Switching Characteristics $V_{DD}=3.3 V$ $V_{DS}=0.8 V$ $V_{IH}=V_{DD}$ $V_{IL}=GND$ $R_{ext}=372 \Omega$ $V_L=4.0 V$ $R_L=64 \Omega$ $C_L=10 pF$ $VG = 0.992$ $CM = 1$	-	100	150	ns
	LE/MOD/CA - \overline{OUTn}	t_{pLH2}		-	100	150	ns
	$\overline{OE}/SW - \overline{OUTn}$	t_{pLH3}		-	100	150	ns
	CLK - SDO	t_{pLH}		45	55	65	ns
Propagation Delay Time ("H" to "L")	CLK - \overline{OUTn}	t_{pHL1}		-	130	200	ns
	LE/MOD/CA - \overline{OUTn}	t_{pHL2}		-	130	200	ns
	$\overline{OE}/SW - \overline{OUTn}$	t_{pHL3}		-	130	200	ns
	CLK - SDO	t_{pHL}		45	55	65	ns
Pulse Width	CLK	$t_{w(CLK)}$		20	-	-	ns
	LE/MOD/CA	$t_{w(L)}$		20	-	-	ns
	\overline{OE}/SW (@ $I_{OUT} < 60mA$)	$t_{w(OE)}$		200	-	-	ns
Hold Time for LE/MOD/CA		$t_{h(L)}$		10	-	-	ns
Setup Time for LE/MOD/CA		$t_{su(L)}$		5	-	-	ns
Maximum CLK Rise Time		t_r		-	-	500	ns
Maximum CLK Fall Time		t_f	-	-	500	ns	
Output Rise Time of Vout (turn off)		t_{or}	-	120	150	ns	
Output Fall Time of Vout (turn on)		t_{of}	-	200	400	ns	
Clock Frequency		F_{CLK}	Cascade Operation	-	-	12.0	MHz

Test Circuit for Electrical Characteristics

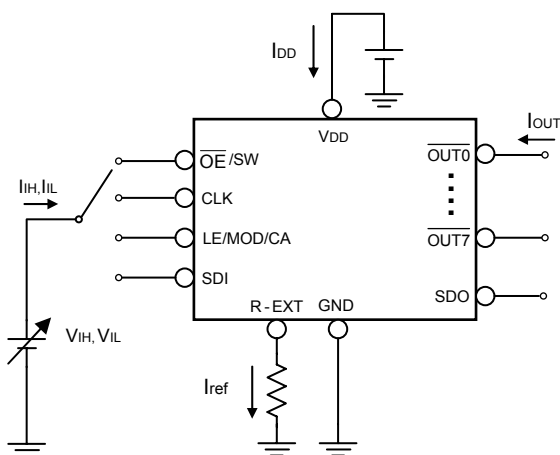

Test Circuit for Switching Characteristics

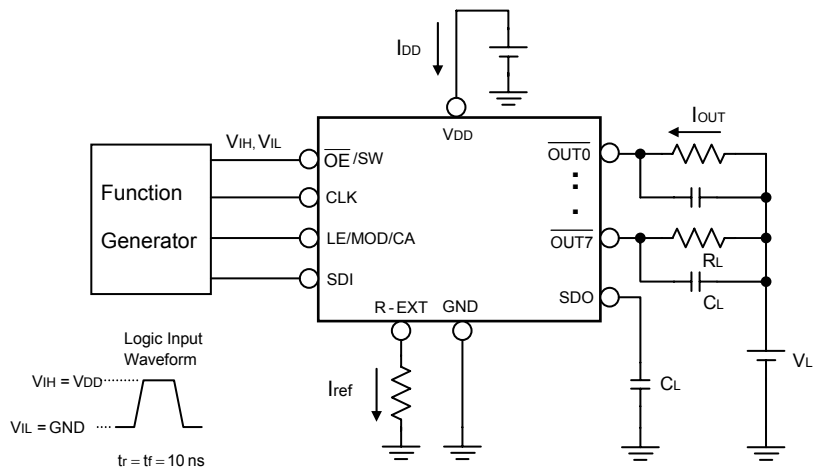

Timing Waveform

Normal Mode and Current Adjust Mode

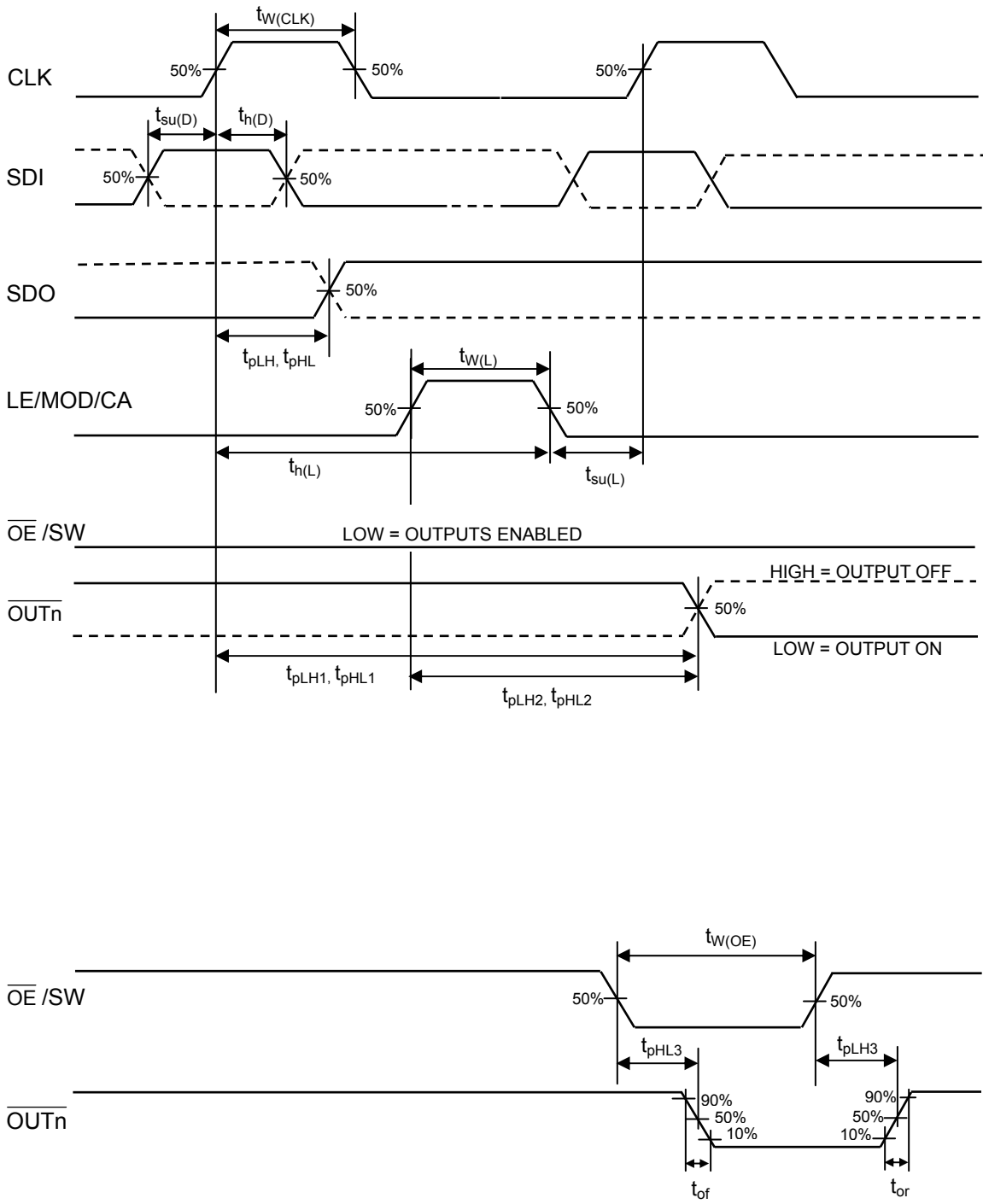

MBI5170 8-Bit Constant Current LED Sink Driver with Gain Control

Switching to Current Adjust Mode

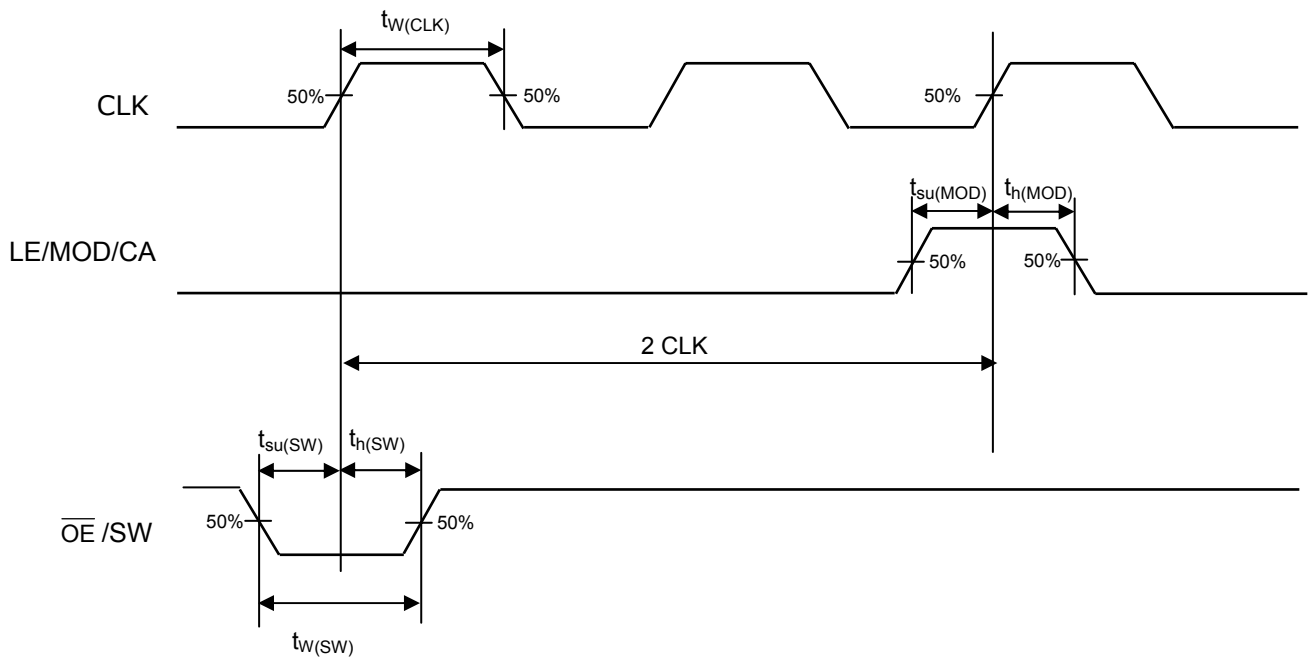

Operation Principle

Constant Current

In LED display applications, MBI5170 provides nearly no current variations from channel to channel and from IC to IC. This can be achieved by:

- 1) While $I_{OUT} \leq 100\text{mA}$, the maximum current skew between channels is less than $\pm 3\%$, and that between IC's is less than $\pm 6\%$.
- 2) In addition, the characteristics curve of output stage in the saturation region is flat and users can refer to the output characteristics figure as shown below. Thus, the output current can be kept constant regardless of the variations of LED forward voltage (V_f).

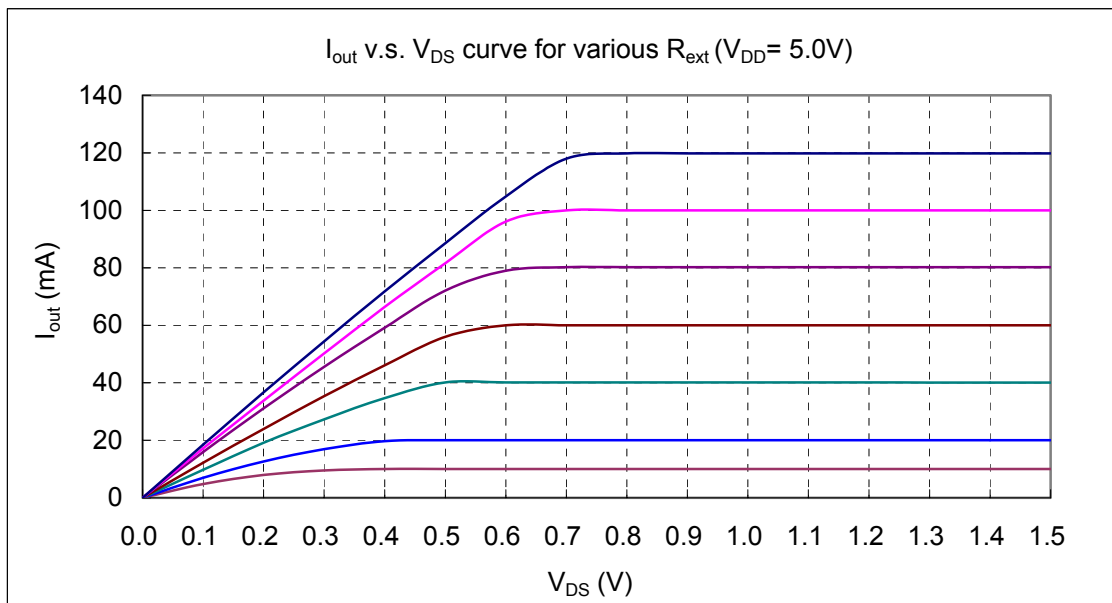

MBI5170 8-Bit Constant Current LED Sink Driver with Gain Control

Adjusting Output Current

MBI5170 scales up the reference current I_{ref} set by the external resistor R_{ext} to sink a current I_{out} at each output port. Users can follow the below formulas to calculate the output current I_{out} in the saturation region:

$$V_{R-EXT} = 1.25\text{Volt} \times VG$$

$$I_{ref} = V_{R-EXT} / R_{ext} \quad \text{if another end of the external resistor } R_{ext} \text{ is connected to ground.}$$

$$I_{out} = I_{ref} \times 15 \times 3^{(CM-1)}$$

where R_{ext} is the resistance of the external resistor connected to the R-EXT terminal, and V_{R-EXT} is the voltage of the R-EXT terminal and controlled by the programmable voltage gain VG, which is defined by the Configuration Code. The Current Multiplier CM would determine that the ratio I_{out}/I_{ref} is 15 or 5. After power-on, the default value of VG is $127/128 = 0.992$ and the default value of CM is 1, so that the ratio I_{out}/I_{ref} is 15. Based on the default VG and CM,

$$V_{R-EXT} = 1.25\text{Volt} \times 127/128 = 1.24\text{Volt}$$

$$I_{out} = (1.24\text{Volt} / R_{ext}) \times 15$$

Hence, the default magnitude of current is around 50mA at 372Ω and 25mA at 744Ω. The default relationship after power-on between I_{out} and R_{ext} is shown in the following figure.

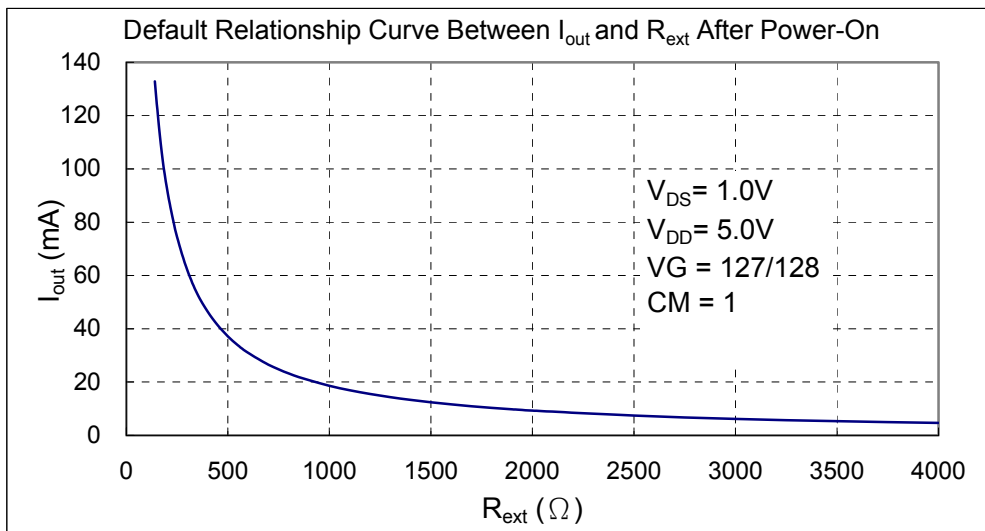

MBI5170 8-Bit Constant Current LED Sink Driver with Gain Control

Operation Phases

MBI5170 exploits the **Share-I-O™** technique to extend the functionality of pins in MBI5168 in order to provide run-time programmable LED driving current in the Current Adjust Mode phase as well as the original function of MBI5168 in the Normal Mode phase. In order to switch between the two modes, MBI5170 monitors the signal \overline{OE}/SW . Once a one-clock-wide pulse of \overline{OE}/SW appears, MBI5170 would enter the two-clock-period transition phase---the Mode Switching phase. After power-on, the default operation mode is the Normal Mode.

Operation Mode Switching

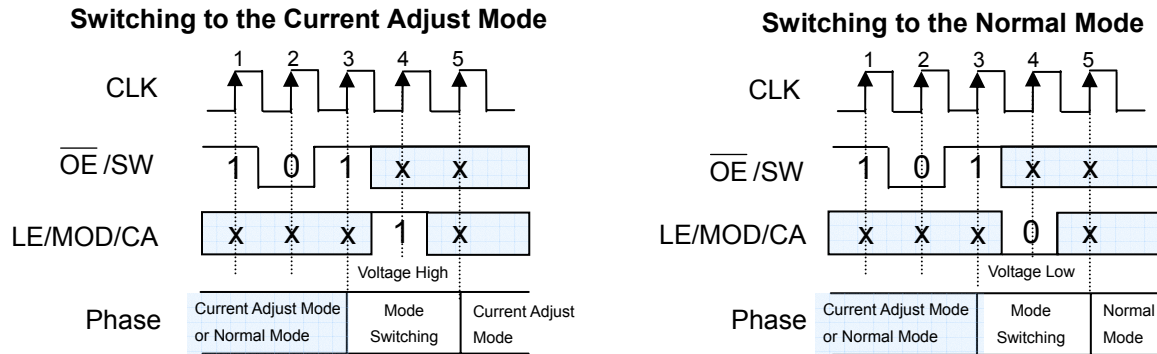

As shown in the above figures, once a one-clock-wide short pulse “101” of \overline{OE}/SW appears, MBI5170 would enter the Mode Switching phase. At the 4th rising edge of CLK, if LE/MOD/CA is sampled as “Voltage High”, MBI5170 would switch to the Current Adjust Mode; otherwise, it would switch to the Normal Mode. Worthwhile noticing, the signal LE/MOD/CA between the 3rd and the 5th rising edges of CLK can not latch any data. Its level is just used for determining which mode to switch. However, the short pulse of \overline{OE}/SW can still enable the output ports. During the mode switching, the serial data can still be transferred through the pin SDI and shifted out from the pin SDO.

Note:

1. The signal sequence for the mode switching could be frequently used for making sure under which mode MBI5170 is working.
2. The aforementioned “1” and “0” are sampled at the rising edge of CLK. The “X” means its level would not affect the result of mode switching mechanism.

Normal Mode Phase

MBI5170 in the Normal Mode phase has similar functionality to MBI5168. The only difference is short pulse \overline{OE}/SW signal monitoring. The short pulse would trigger MBI5170 to switch its operation mode. However, as long as the signal LE/MOD/CA is not Voltage High in the Mode Switching phase, MBI5170 would still remain in the Normal Mode as if no mode switching occurs.

MBI5170 8-Bit Constant Current LED Sink Driver with Gain Control

Current Adjust Mode Phase and Writing Configuration Code

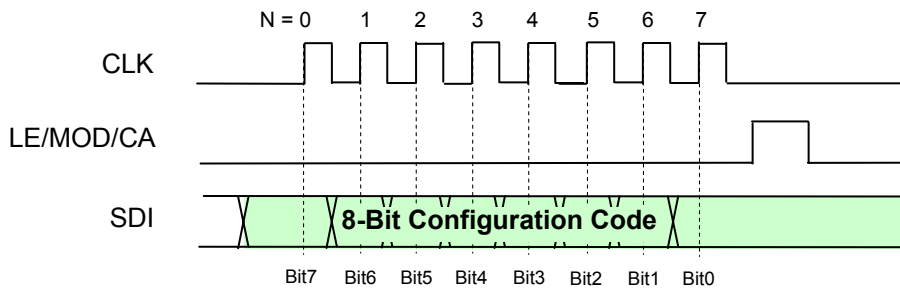

In the Current Adjust Mode phase, the serial data could be transferred into MBI5170 via the pin SDI, shifted in the Shift Register, and go out via the pin SDO. The active low signal \overline{OE}/SW can enable the output drivers to sink current. These are the same as those in the Normal Mode. The difference is that the active high signal LE/MOD/CA latches the serial data in the Shift Register to the Configuration Latch, instead of the Output Latch. The latched serial data is regarded as the Configuration Code. The code would be memorized until power off or the Configuration Latch is re-written. As shown above, the timing for writing the Configuration Code is the same as that in the Normal Mode for latching output channel data.

8-Bit Configuration Code and Current Gain CG

Bit Definition of 8-Bit Configuration Code								
	Bit 0	Bit 1	Bit 2	Bit 3	Bit 4	Bit 5	Bit 6	Bit 7
Meaning	CM	HC	CC0	CC1	CC2	CC3	CC4	CC5
Default Value	1	1	1	1	1	1	1	1

Bit definition of the Configuration Code in the Configuration Latch is shown above. Bit 7 is first sent into MBI5170 via the pin SDI. Bit 1 ~ 7, {HC, CC[0:5]}, would determine the voltage gain (VG), that affects the voltage at R-EXT terminal and indirectly the reference current I_{ref} flowing through the external resistor at terminal R-EXT. Bit 0 is the Current Multiplier (CM) bit, that determines the ratio $I_{\text{out}}/I_{\text{ref}}$. Each combination of VG and CM would give a Current Gain (CG).

- VG: the relationship between {HC, CC[0:5]} and the Voltage Gain G can be formulated as below:

$$VG = (1 + HC) \times (1 + D/64) / 4$$

$$D = CC0 \times 2^5 + CC1 \times 2^4 + CC2 \times 2^3 + CC3 \times 2^2 + CC4 \times 2^1 + CC5 \times 2^0$$

where HC is 1 or 0, and D is the binary value of CC[0:5]. So, the VG could be regarded as a floating-point number with one bit exponent HC and 6-bit mantissa CC[0:5]. {HC, CC[0:5]} divides the programmable voltage gain VG into 128 steps and two sub-bands:

Low voltage sub-band (HC=0): $VG = 1/4 \sim 127/256$, linearly divided into 64 steps;

High voltage sub-band (HC=1): $VG = 1/2 \sim 127/128$, linearly divided into 64 steps, too.

- CM: as well as determining the ratio $I_{\text{out}}/I_{\text{ref}}$, the CM bit would limit the output current range.

High Current Multiplier (CM=1): $I_{\text{out}}/I_{\text{ref}} = 15$ and suitable for output current range $I_{\text{out}} = 10 \sim 120\text{mA}$.

Low Current Multiplier (CM=0): $I_{\text{out}}/I_{\text{ref}} = 5$ and suitable for output current range $I_{\text{out}} = 5 \sim 40\text{mA}$.

MBI5170 8-Bit Constant Current LED Sink Driver with Gain Control

- CG: the total Current Gain is defined as the following.

$$V_{R-EXT} = 1.25\text{Volt} * VG$$

$$I_{rext} = V_{R-EXT} / R_{ext} \quad \text{if another end of the external resistor } R_{ext} \text{ is connected to ground.}$$

$$I_{out} = I_{rext} * 15 * 3^{(CM-1)} = 1.25\text{Volt} / R_{ext} * VG * 15 * 3^{(CM-1)} = (1.25\text{Volt} / R_{ext} * 15) * CG$$

We define $CG = VG * 3^{(CM-1)}$. Hence $CG = (1/12) \sim (127/128)$ and it is divided into 256 steps, totally. If

$CG = 127/128 = 0.992$, the I_{out} - R_{ext} relationship is similar to that in MBI5168.

For example,

- When the Configuration Code $\{CM, HC, CC[0:5]\} = \{1, 1, 111111\}$,
 $VG = 127/128 = 0.992$; and $CG = VG * 3^0 = VG = 0.992$
- When the Configuration Code is $\{1, 1, 000000\}$,
 $VG = (1+1)*(1+0/64)/4 = 1/2 = 0.5$; and $CG = 0.5$
- When the Configuration Code is $\{0, 0, 000000\}$,
 $VG = (1+0)*(1+ 0/64)/4 = 1/4$; and $CG = (1/4)*3^{-1} = 1/12$

After power on, the default value of the Configuration Code $\{CM, HC, CC[0:5]\}$ is $\{1, 1, 111111\}$. Thus, $VG = CG = 0.992$. The relationship between the Configuration Code and the Current Gain CG is shown in the following.

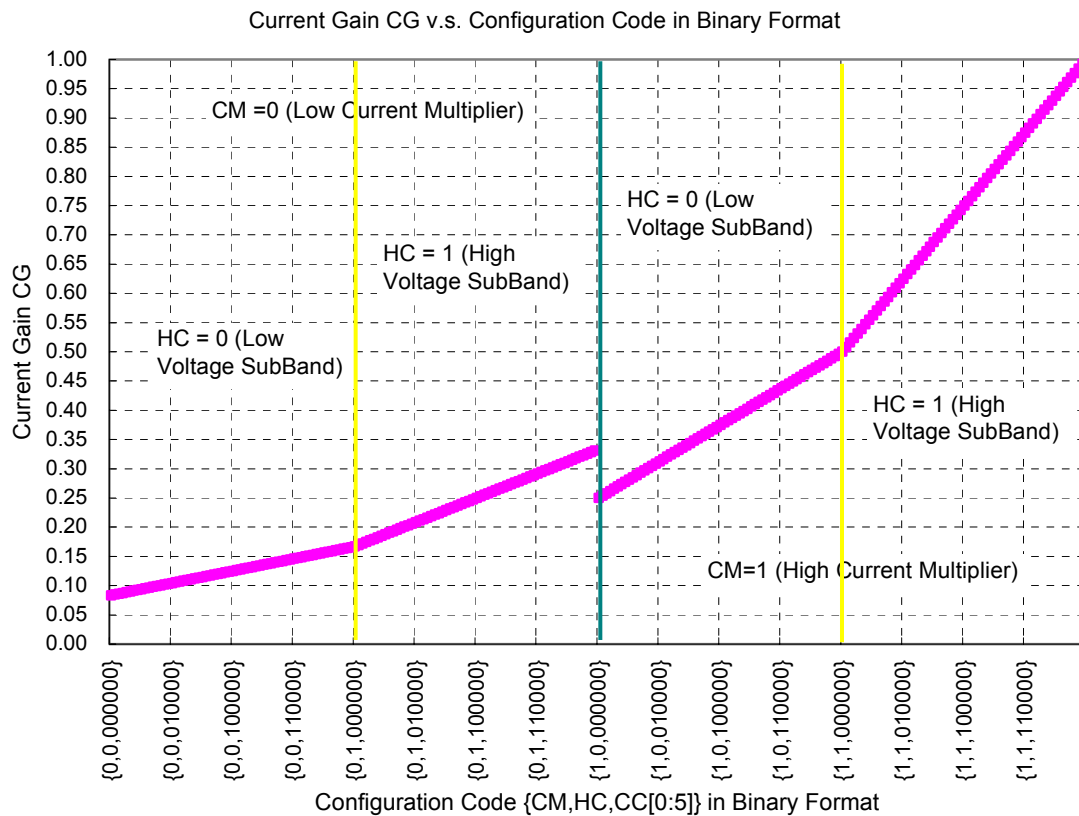

Timing Chart for Current Adjust Mode (An Example)

N of MBI5170 are connected in cascade, i.e., SDO, k --> SDI, k+1.
 And, all MBI5170 are connected to the same signal bus CLK, LE/MOD/CA and \overline{OE}/SW .

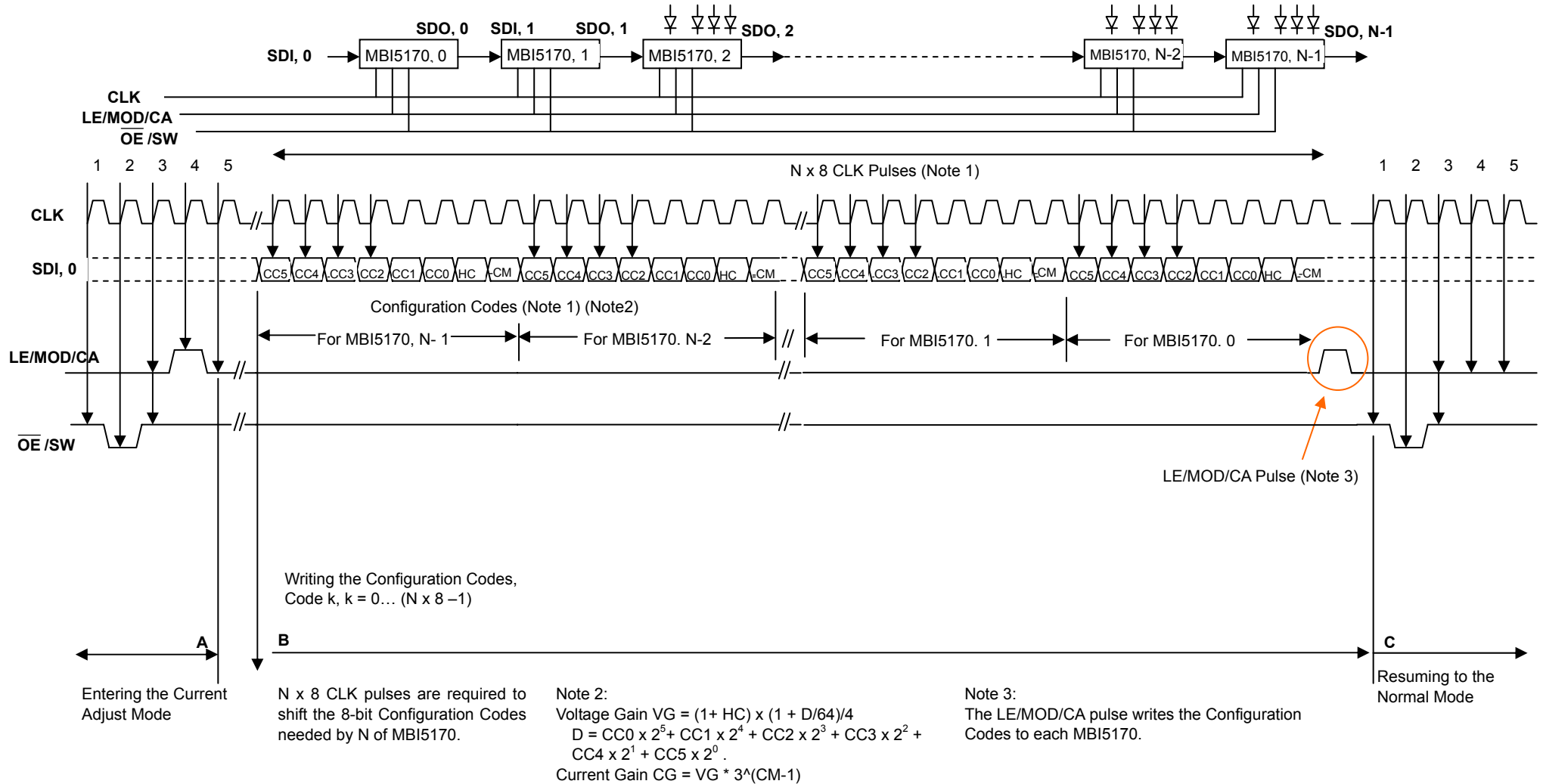

Application Information

Soldering Process of “Pb-free & Green” Package Plating*

Macroblock has defines "Pb-Free & Green" to mean semiconductor products that are compatible with the current RoHS requirements and selected **100% pure tin (Sn)** to provide forward and backward compatibility with both the current industry-standard SnPb-based soldering processes and higher-temperature Pb-free processes. Pure tin is widely accepted by customers and suppliers of electronic devices in Europe, Asia and the US as the lead-free surface finish of choice to replace tin-lead. Also, it is backward compatible to standard 215°C to 240°C reflow processes which adopt tin/lead (SnPb) solder paste. However, in the whole Pb-free soldering processes and materials, 100% pure tin (Sn), will all require up to 260°C for proper soldering on boards, referring to J-STD-020B as shown below.

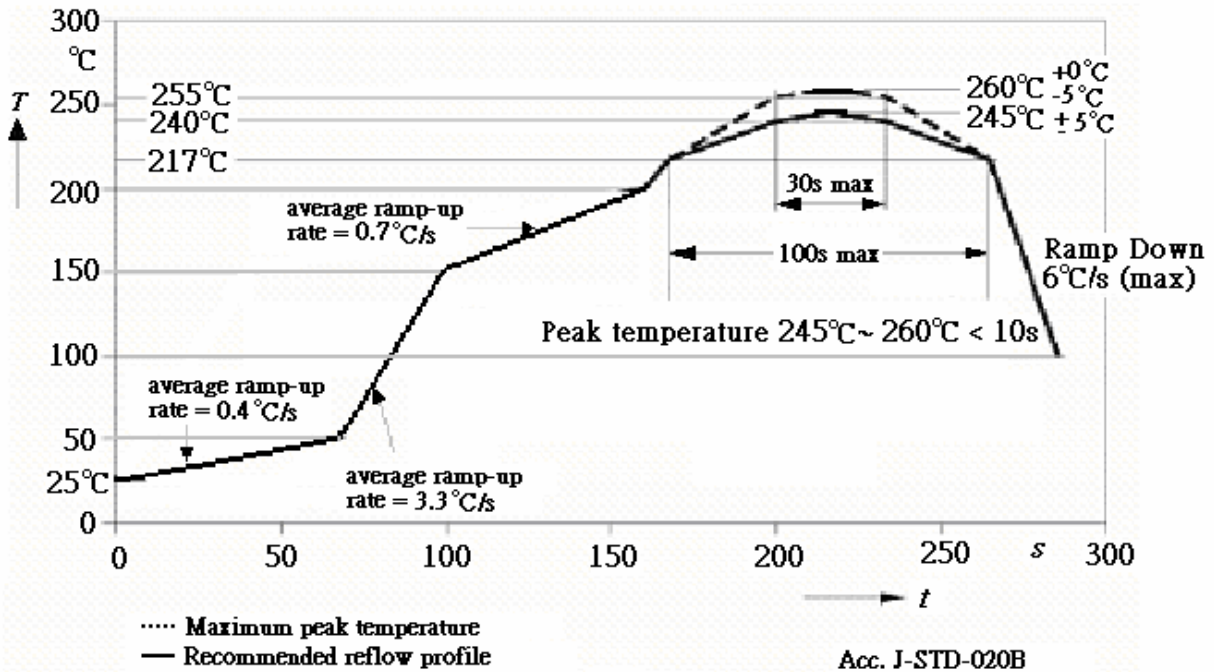

*Note1: For details, please refer to Macroblock’s “Policy on Pb-free & Green Package”.

MBI5170 8-Bit Constant Current LED Sink Driver with Gain Control

Package Power Dissipation (P_D)

The maximum allowable package power dissipation is determined as $P_{D(max)} = (T_j - T_a) / R_{th(j-a)}$. When 8 output channels are turned on simultaneously, the actual package power dissipation is

$$P_{D(act)} = (I_{DD} \times V_{DD}) + (I_{OUT} \times Duty \times V_{DS} \times 8)$$

Therefore, to keep $P_{D(act)} \leq P_{D(max)}$, the allowable maximum output current as a function of duty cycle is

$$I_{OUT} = \{ [(T_j - T_a) / R_{th(j-a)}] - (I_{DD} \times V_{DD}) \} / V_{DS} / Duty / 8$$

where $T_j = 150^\circ\text{C}$.

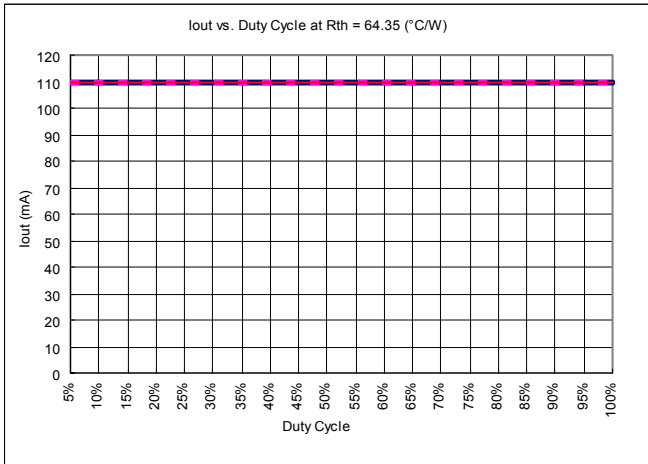

CN\GN Device Type

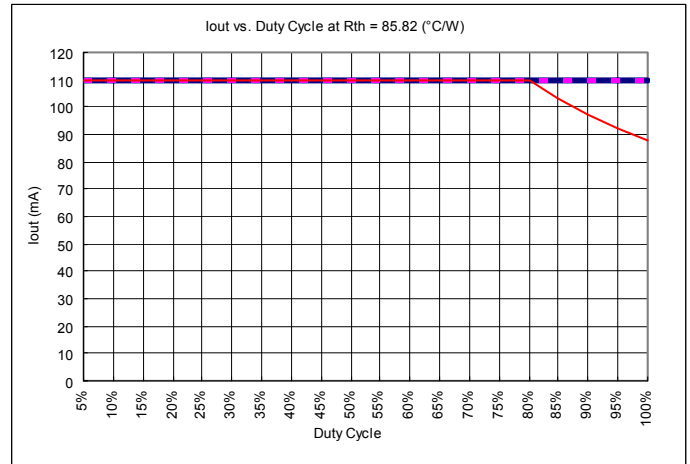

CD\GD Device Type

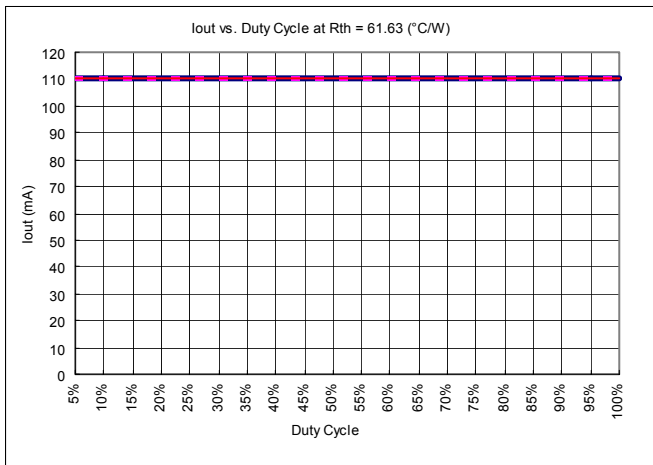

CDW\GDW Device

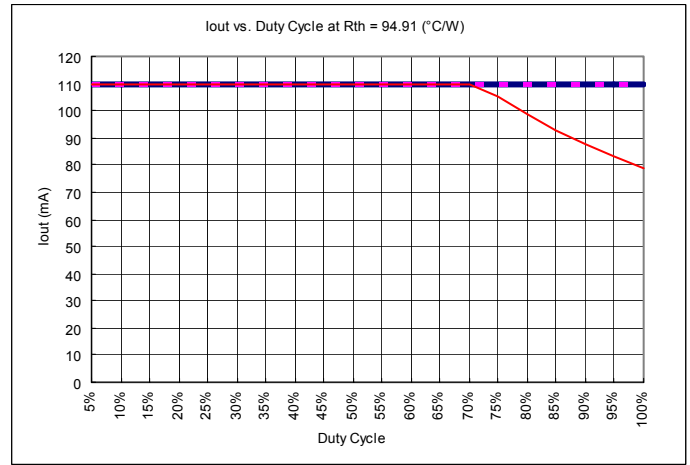

CP\GP Device Type

Condition : $V_{DS} = 1.0\text{V}$, $V_{DD} = 5.0\text{V}$, 8 output channels active, T_a is listed in the legend below.				
Device Type		$R_{th(j-a)}$ ($^\circ\text{C/W}$)		Note
CN	GN	64.35	60.20	
CD	GD	85.82	70.14	
CDW	GDW	61.63	68.67	
CP	GP	94.91	80.00	

MBI5170 8-Bit Constant Current LED Sink Driver with Gain Control

Load Supply Voltage (V_{LED})

Considering the package power dissipating limits, users had better apply MBI5170 to operate within $V_{DS} = 0.4V \sim 1.0V$. If V_{LED} is higher, for instance, than 5V, V_{DS} may be so high that $P_{D(Act)} > P_{D(Max)}$, where $V_{DS} = V_{LED} - V_F$. In this case, it is recommended to use as low supply voltage as possible or to arrange a voltage reducer, V_{DROP} . The voltage reducer lets $V_{DS} = (V_{LED} - V_F) - V_{DROP}$. Resistors or Zener diodes can be used as the reducers in the applications as shown in the following figures.

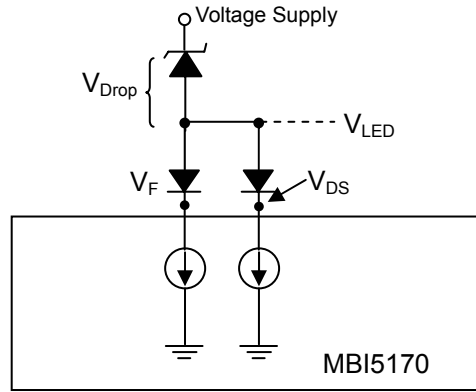
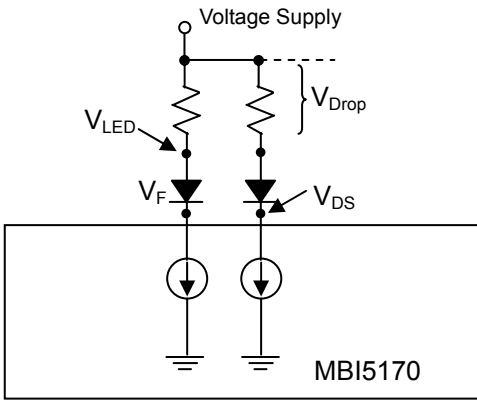

Switching Noise Reduction

LED Driver ICs are frequently used in switch-mode applications which always behave with switching noise due to parasitic inductance on PCB. To eliminate switching noise, refer to "Application Note for 8-bit and 16-bit LED Drivers- Overshoot".

Outline Drawings

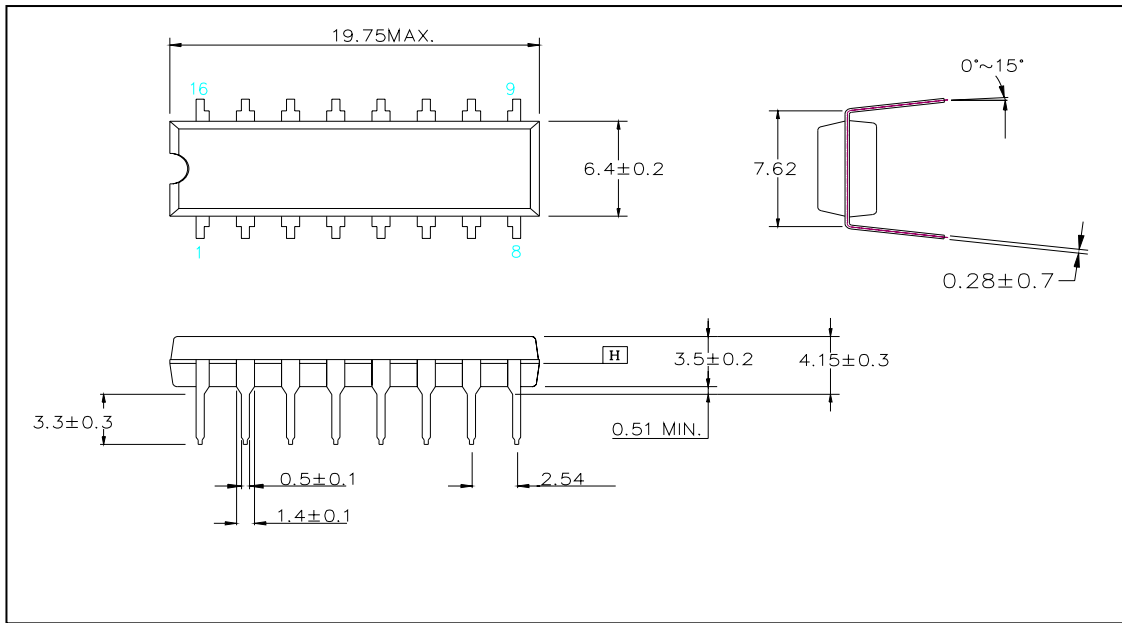

MBI5170CNGN Outline Drawing

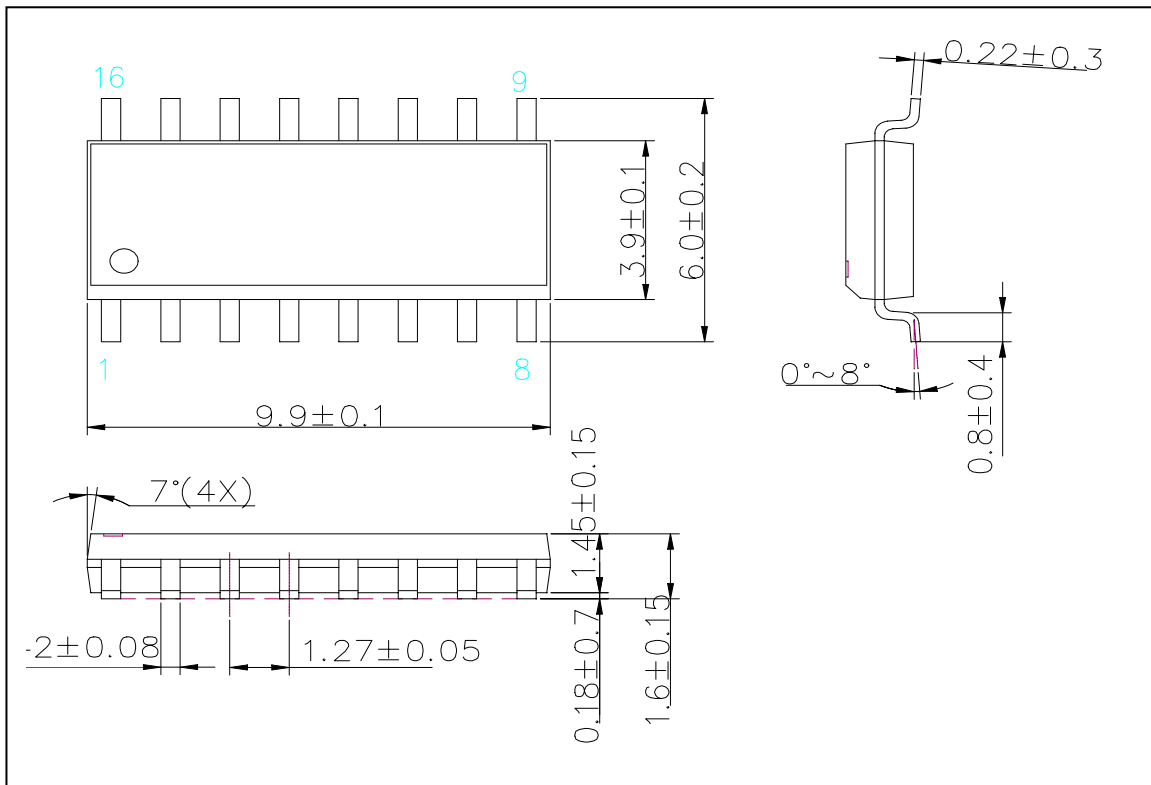

MBI5170CDVGD Outline Drawing

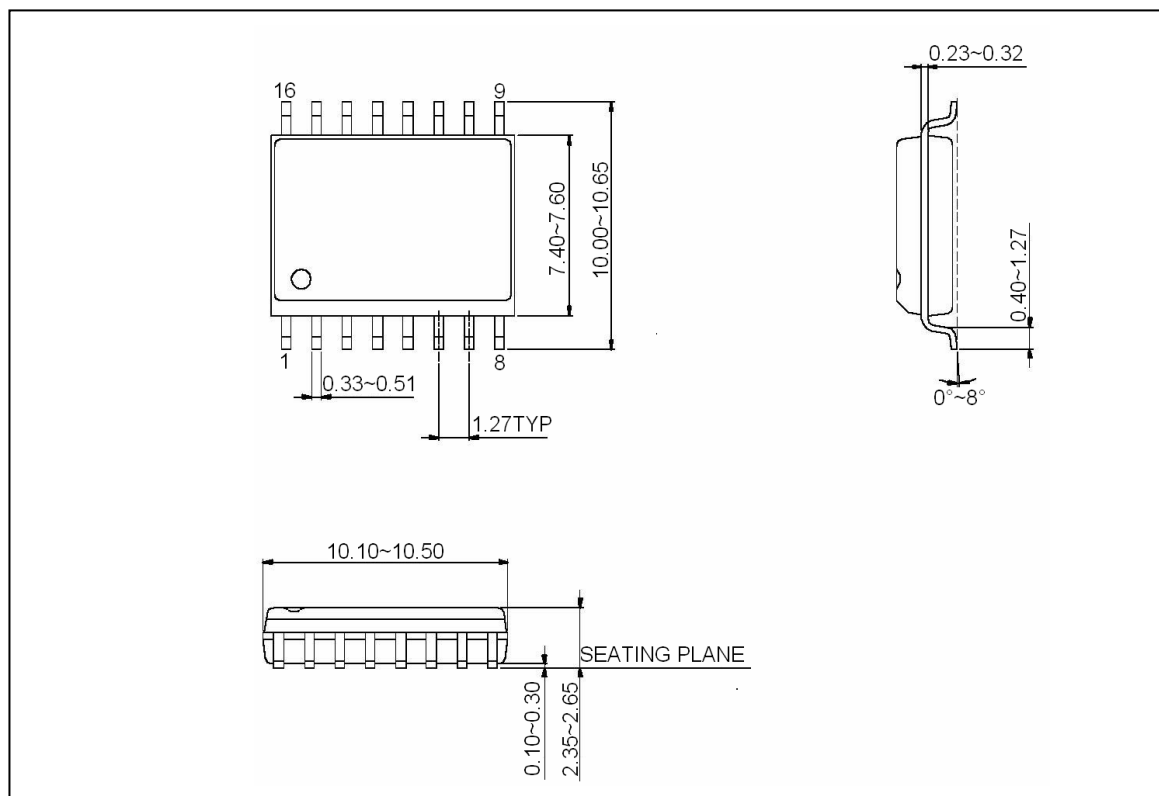

MBI5170CDW\GDW Outline Drawing

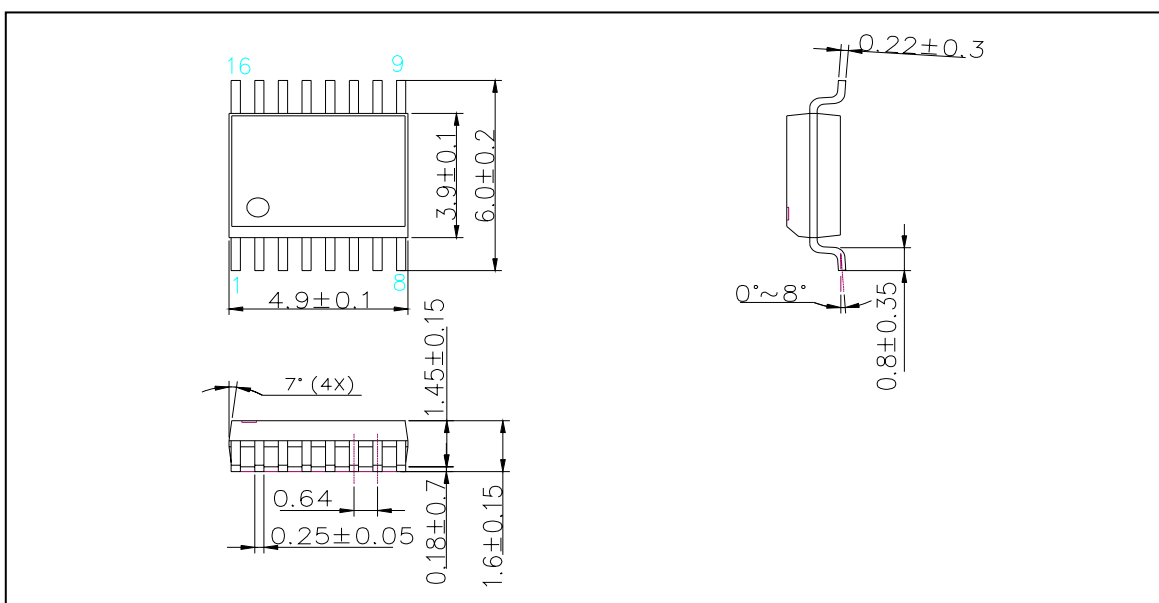

MBI5170CP\GP Outline Drawing

Note: The unit for the outline drawing is mm.

MBI5170 8-Bit Constant Current LED Sink Driver with Gain Control

Product Top-mark Information

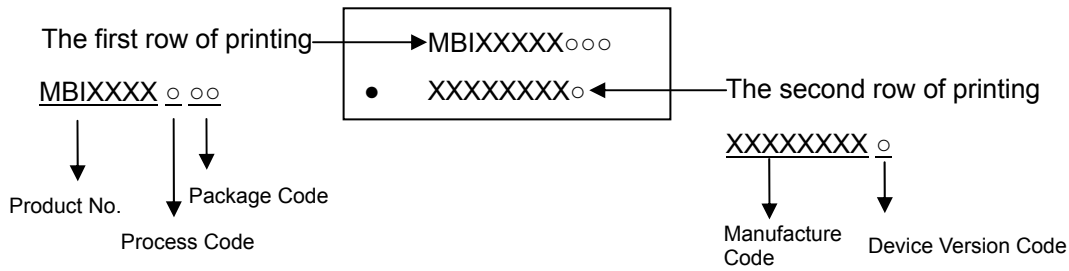

Product Revision History

Datasheet version	Device version code
VA.00	<i>Not defined</i>
VA.02	A

Product Ordering Information

Part Number	Package Type	Weight (g)
MBI5170CN	P-DIP16-300-2.54	1.02
MBI5170CD	SOP16-150-1.27	0.13
MBI5170CDW	SOP16-300-1.27	0.37
MBI5170CP	SSOP16-150-0.64	0.07

Part Number	"Pb-free & Green" Package Type	Weight (g)
MBI5170GN	P-DIP16-300-2.54	1.02
MBI5170GD	SOP16-150-1.27	0.13
MBI5170GDW	SOP16-300-1.27	0.37
MBI5170GP	SSOP16-150-0.64	0.07