

REVISION RECORD			
REV	ECD	DESCRIPTION	DRFT DATE
Δ	10-0303	增加“0E”零件认证标准及参数变更	Jinlai Lan 09/16/10*
Δ	10-0320	DEGSON-2.5端子打样(10220000片) (仅限 DEBMD-2.5 产品)	HXG 09/27/10*

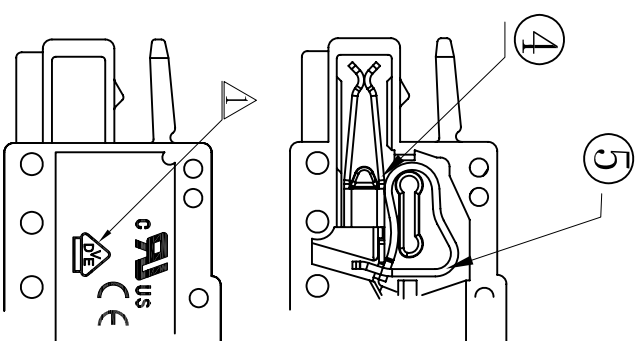

- Notes:
- Pitch: 2.50mm
 - Rated voltage/current: UL 150V 4A
VDE 250V 4A
 - Operation temperatures: -40°C ~ +105°C
 - Withstanding Voltage: AC2000V/1Min
 - Insulation Resistance: 5000MΩ/DC1000V
 - Wire Range: 28~20AWG, 0.5mm²
 - Undimensioned Tolerances:

Pitch range in mm	Normal dimension range in mm	—
over 6	over 50	over 150
to 10	to 60	to 100
to 24	to 30	to 60
to 10	to 100	to 150
H0.10	H0.25 ± 0.2	H0.5 ± 0.7 ± 1
		0.05mm

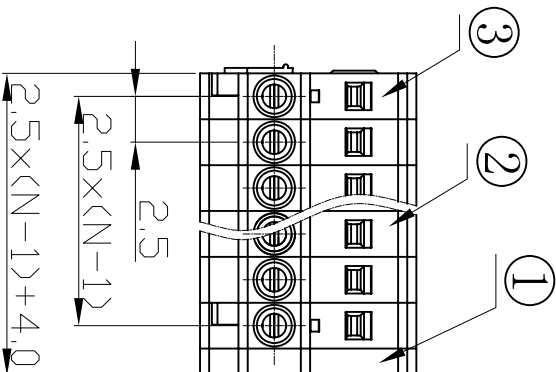
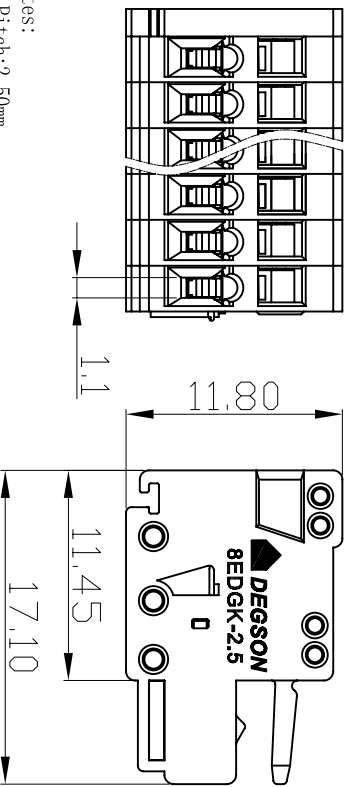
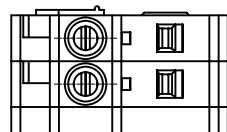
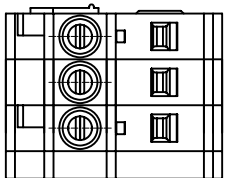
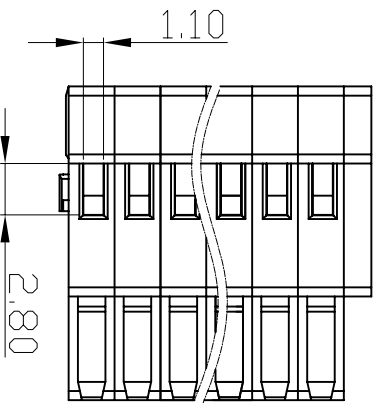
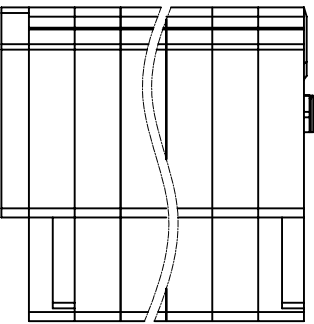

ITEM	DESCRIPTION	XX	Material	UL
5	8EDGK-2.5-Spring	XX	Stainless Steel	UL94V-0
4	8EDGK-2.5 Clamp	XX	Phosphor Bronze	
3	8EDGK-2.5 Housing ²	2	PA66	

DETACHED LISTS		THIRD ANGLE PROJECTION		SCALE	
1	8EDGK-2.5 Cover	1127C0Y01A (H)	1	Q"TY	MATERIAL
2	8EDGK-2.5 Housing ¹	1127A0Y01A (H)	1		

NAME	DEGSON 宁波高正电子有限公司
DEGSON	DEGSON ELECTRONICS CO., LTD
NAME	8EDGK-2.5-XXP-1Y-00A(H)
DRAWING NO.	8EDGK-2.5-E02
/PART NO.	
DD NOT SCALE DRAWING	
SHEET	1 OF 1

8 7 6 5 4 3 2 1