

Installation Instructions for the AWM40000 Series Mass Gas-Flow Sensors

ISSUE 4
PK 80005

GENERAL INFORMATION

AWM40000 Series microbridge mass gas-flow sensors operate on the theory of heat transfer due to mass gas-flow across the surface of the sensing element. The sensing element consists of a resistor bridge heater circuit and dual temperature-sensing resistor bridges. This configuration senses mass flow rates and flow direction. Amplified or unamplified sensor outputs are available. The **unamplified** sensors require additional customer supplied circuitry (Figures 1 and 2). The Figure 3 circuit and Equation 1 may be used to increase gain and introduce voltage offsets to the sensor output. **Amplified** sensors contain all necessary circuitry for heater control, sensing bridge supply, and amplifier functions.

MASS FLOW VS. DIFFERENTIAL PRESSURE SENSING

As flow passes through the sensor, the internal flow restriction creates a pressure drop. The greater the differential pressure, the greater the flow passing through the sensor. When measuring differential pressure, the output varies proportionately to the absolute density change of the media gas. Variations in gas density due to barometric pressure or temperature changes will affect sensor output.

DESCRIPTION

Catalog Listing	Flow Range
AWM42150VH	± 25 sccm/± 0.008 in H ₂ O
AWM42300V	± 1000 sccm/± 1.0 in H ₂ O
AWM43300V	+ 1000 sccm/+ 1.0 in H ₂ O
AWM43600V	+ 6 SLPM/+ 8.0 in H ₂ O

NOTICE

Media flow through the sensor should be free of condensing moisture and particulates. Large, high-velocity particles or conductive particles may damage the sensing element. Use of an inexpensive 5 micron filter, upstream of the sensing element, is recommended.

Figure 1, Heater Control Circuit

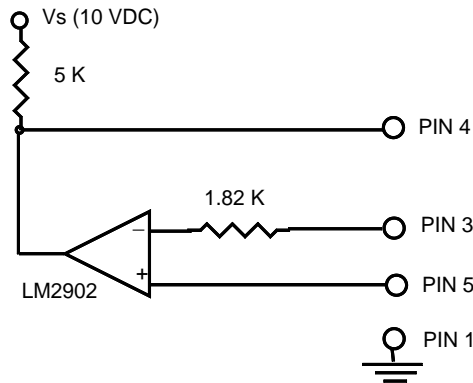

Figure 2, Sensing Bridge Supply Circuit

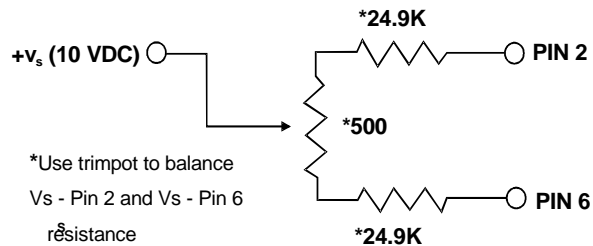
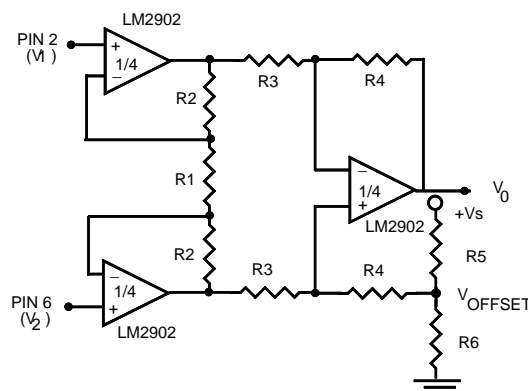

Figure 3, Differential Instrumentation Amplifier (Optional)



Equation 1

$$V_O = \frac{2R_2 + R_1}{R_1} \frac{R_4}{R_3} (V_2 - V_1) + V_{\text{offset}}$$

where

$$V_{\text{offset}} = V_S \frac{R_6}{R_6 + R_5}$$

SPECIFICATIONS

Catalog Listing	AWM42150VH			AWM42300V			AWM43300V			AWM43600V		
Flow Range (Full scale)	± 25 sccm			± 1000 sccm			+ 1000 sccm			+ 6 SLPM		
Output Voltage (mV) @ Trim Point	8.5 mV ± 1.5 mVdc @ 25 sccm			55.2 mV ± 2.0 mVdc @ 1000 sccm			5.0 V ± 0.15.0 Vdc @ 1000 sccm			5.0 V ± 0.15.0 Vdc @ 6 SLPM		
Null Voltage	0.0 mV ± 1.0 mVdc			0.0 mV ± 1.0 mVdc			1.0 V ± 0.05 Vdc			1.0 ± 0.05 Vdc		
Null Voltage Shift, 25 °C to -25 °C, 25 °C to 85 °C	± 0.2 mVdc (typ.)			± 0.2 mVdc (typ.)			± 0.025 Vdc (max.)			± 0.050 Vdc (max.)		
Output Voltage Shift 25 °C to -25 °C 25 °C to 85 °C	2.5% Reading (typ.) -2.5% Reading (typ.)			2.5% Reading (max.) -2.5% Reading (max.)			-5% Reading (max.) 6% Reading (max.)			-7% Reading (max.) 7% Reading (max.)		
Power Consumption (mW)	40 mw (max) @ 85 °C			50 mw (max) @ 85 °C			60 mw (max) @ 85 °C			75 mw (max) @ 85 °C		
Repeatability & Hysteresis (3)	± 0.35% Reading			± 0.35% Reading			± 0.50% Reading			± 1.00% Reading		
Pressure Drop @ Full Scale (in. of H ₂ O)	0.008 (typ.)			1.02 (typ.)			1.02 (typ)			8.00 (typ)		
	Min.	Typ.	Max.	Min.	Typ.	Max.	Min.	Typ.	Max.	Min.	Typ.	Max.
Excitation VDC (2)	8.0	10±.01	15	8.0	10±.01	15	8.0	10±.01	15	9.99	10±.01	15 (5)
Max. Common Mode Pressure (psi) (4)	250 (max.)			250 (max.)			250 (max.)			25 (max.)		
Ratiometricity Error	± 0.35% Reading, typ. (2)									± 0.8% Reading, typ. (2)		
Temperature Range	Operating: -40 °C to 125 °C [-40 °F to 257 °F] Storage: -40 °C to 125 °C [-40 °F to 257 °F]						Operating: -25 °C to 85 °C [-13 °F to 185 °F] Storage: -40 °C to 125 °C [-40 °F to 257 °F]					
Response Time (msec)	1 msec (typ.), 3 msec (max.) (1)											
Output Load	Sinking: 10 mA Sourcing: 20 mA											
Calibration gas	Nitrogen											
Weight (grams)	17.5 grams (typ.) [0.62 oz] includes 43 grams for backing plate											
Shock Rating	100 g peak (5 drops, 6 axes)											
Termination	2.5 mm [0.100 in] centers, 0.635 mm [0.025 in] square											

Notes:

1. Response time is typically 1 ms from 10% to 90%.
2. Output voltage is ratiometric to supply voltage.
3. Repeatability & Hysteresis tolerances reflect inherent inaccuracies of the measurement equipment.
4. Maximum rate of flow change to prevent damage: 5 SLPM/sec.
5. 11.0 Vdc minimum excitation required for operation within specification above 50 °C

MOUNTING DIMENSIONS (for reference only) mm/in

Unamplified Sensors

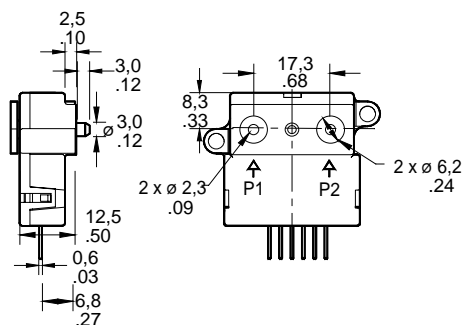
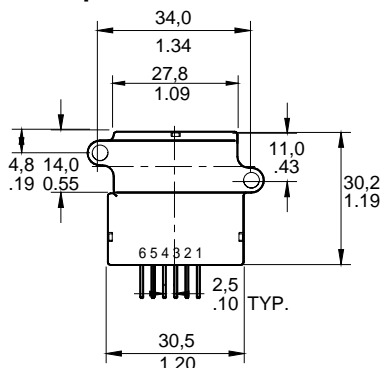

Amplified Sensors

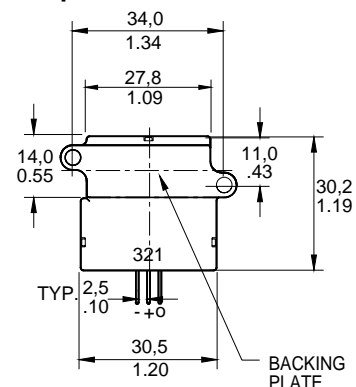

NOTE: Positive flow direction is defined as proceeding into Port 1 (P1) and out of Port 2 (P2), resulting in positive output (Pin 6 > Pin 2). Negative flow direction is defined conversely and results in negative output (Pin 6 < Pin 2).

OUTPUT FLOW VS INTERCHANGEABILITY

AWM42150VH			AWM42300V			AWM43300V			AWM43600V		
Flow sccm	Nom mVdc	TOL ± mVdc	Flow sccm	Nom mVdc	TOL ± mVdc	Flow sccm	Nom mVdc	TOL ± mVdc	Flow SLPM	Nom mVdc	TOL ± mVdc
25	8.50	1.5	1000	55.2	2.0	1000	5.00	0.15	6	5.00	0.15
20	6.80	1.5	800	53.0	2.0	900	4.97	0.16	5	4.89	0.20
15	5.20	1.0	600	49.3	2.5	800	4.89	0.17	4	4.70	0.25
10	3.50	1.0	400	42.5	3.5	700	4.78	0.18	3	4.40	0.35
5	1.70	1.0	200	29.8	4.0	600	4.63	0.19	2	3.80	0.30
0	0.00	1.0	0	0.0	1.5	500	4.43	0.20	1	3.10	0.30
			-200	-29.8	4.0	400	4.15	0.21	0	1.00	0.05
			-400	-42.5	5.0	300	3.76	0.19			
			-600	-49.3	6.0	200	3.23	0.17			
			-800	-53.0	6.0	100	2.49	0.14			
			-1000	-55.2	6.0	0	1.00	0.05			

OUTPUT CURVES

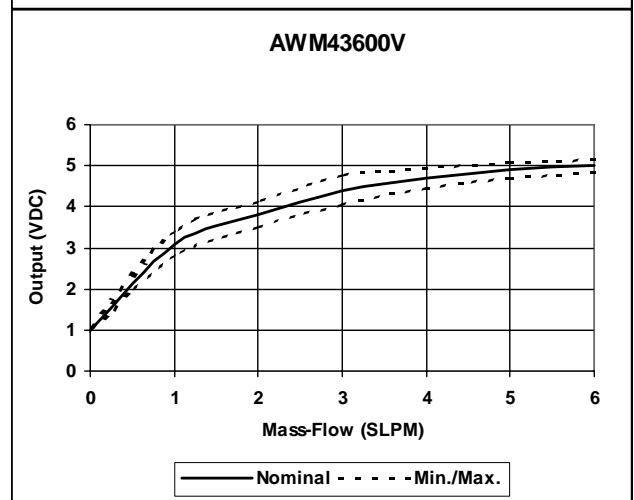
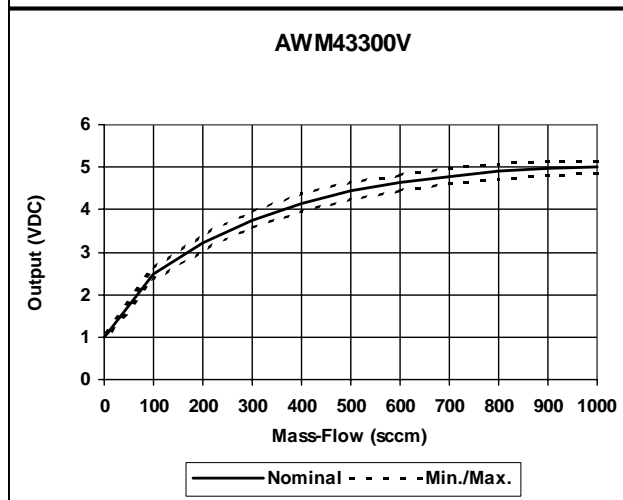
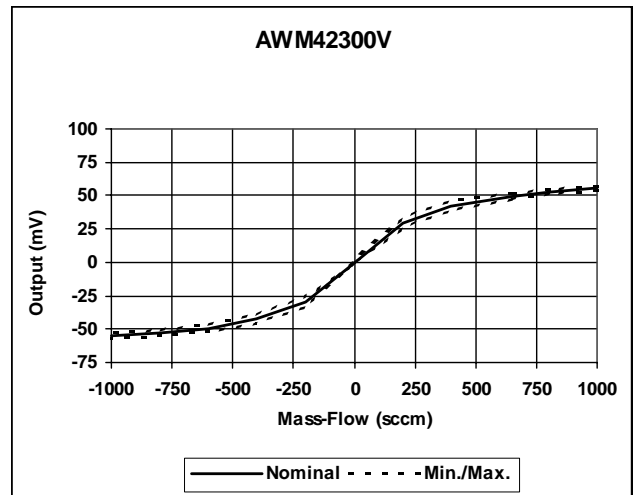
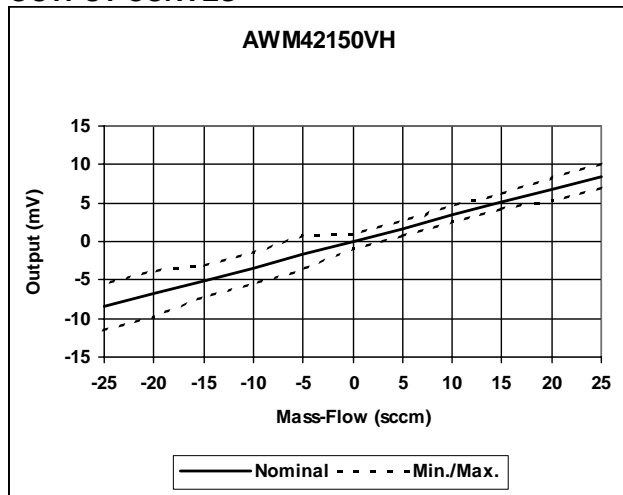

MOUNTING

NOTICE

1. Recommended mounting torque: 0.3 Nm to 0.7 Nm. [3.0 in./lbs to 6.0 in./lbs]
2. Backing-plate (included) is required for use with common mode pressures in excess of 25 psi.
3. To achieve optimum sealing, insert one O-ring (2 Viton 75 Durometer included) into each sensor flow port (**P1** and **P2**). O-ring industry standard 2-006 (recommended Durometer 60 to 75).
4. Mount as follows to help prevent misalignment and improper sealing.
 - a. Insert both mounting screws and lightly tighten.
 - b. Apply recommended mounting torque to both mounting screws.

SOLDERING

NOTICE

Securely attach sensor to PC board before soldering.

Hand Soldering: Use temperature controlled soldering iron with 3,2 mm [1/8 in.] diameter tip. Set temperature at 400 °C [750 °F]. Hold tip on terminal for five seconds maximum. Use type "R" flux rosin core solder.

Wave Solder: Set solder temperature at 250 °C [480 °F] maximum. Minimum drive speed should be 1.54 m [5 ft.] per minute.

CLEANING

NOTICE

Do not use ultrasonic cleaning. This may damage the microstructure. Cover flow ports P1 and P2 during any cleaning operation. Certain solvents may attack the epoxy used to attach the microstructure to the ceramic substrate.

WARRANTY/REMEDY

Honeywell warrants goods of its manufacture as being free of defective materials and faulty workmanship. Contact your local sales office for warranty information. If warranted goods are returned to Honeywell during the period of coverage, Honeywell will repair or replace without charge those items it finds defective. The foregoing is Buyer's sole remedy and is **in lieu of all other warranties, expressed or implied, including those of merchantability and fitness for a particular purpose.**

Specifications may change without notice. The information we supply is believed to be accurate and reliable as of this printing. However, we assume no responsibility for its use.

While we provide application assistance personally, through our literature and the Honeywell web site, it is up to the customer to determine the suitability of the product in the application.

For application assistance, current specifications, or name of the nearest Authorized Distributor, contact a nearby sales office. Or call:

1-800-537-6945 USA

1-800-737-3360 Canada

1-815-235-6847 International

FAX

1-815-235-6545 USA

INTERNET

www.honeywell.com/sensing

info.sc@honeywell.com

Honeywell

Sensing and Control

Honeywell

11 West Spring Street

Freeport, Illinois 61032

PK 80005-4 EN IL50 GLO 303 Printed in USA

www.honeywell.com/sensing