



EXCEED PERSEVERANCE ELECTRONIC INDUSTRY CO., LTD.

深圳市超毅光电子有限公司

φ 3.0 mm ROUND TYPE WITH FLANGE LEDS.

Part Number:

RL30-RD314S

RL30-SR114S

RL30-HO314S

RL30-HY214S

RL30-YG414S

RL30-SO424S

Features

1. LOW POWER CONSUMPTION.
2. RELIABLE AND RUGGED.
3. EXCELLENT UNIFORMITY OF LIGHT OUTPUT.
4. SUITABLE FOR LEVEL INDICATOR.
5. I.C COMPATIBLE.
6. LONG LIFE-SOLIDSTATE RELIABILITY.

Notes:

1. All dimensions are in millimeters (inches)
2. Tolerance is $\pm 0.25(0.01'')$ unless otherwise niter
3. Lead spacing is measured where the lead emerge package
4. Specifications are subject to change without notice

Package Dimensions

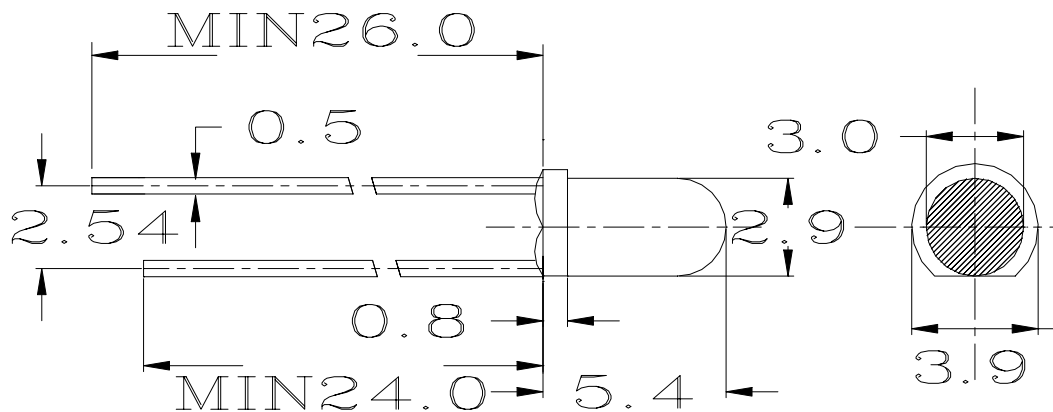

Selection Guide

Part NO.	Lens Type	Chip			
		Material	IV (mcd)		Viewing Angle
			@10mA	*20mA	
Min.	Typ.	2 θ 1/2			
RL30-RD314S	Bright Red Diffused	GaP/GaP	1.2	2.0	75°
RL30-SR114S	Super Red Diffused	GaAlAs/GaAs	16	30	75°
RL30-HO314S	Orange Red Diffused	GaAsP/GaP	10	22	75°
RL30-HY214S	Yellow Diffused	GaAsP/GaP	12	20	75°
RL30-YG414S	Yellow Green Diffused	GaP/GaP	12	20	75°
RL30-SO424S	Super Amber Transparent	GaAsP/GaP	18	31	30°

1. θ 1/2 is the angle from optical centerline where the luminous intensity is 1/2 the optical centerline value.

2. *Luminous intensity with measured at 20mA.



EXCEED PERSEVERANCE ELECTRONIC INDUSTRY CO., LTD.

深圳市超毅光电子有限公司

Electrical/Optical characteristics at TA=25°C.

Symbol	Parameter	Device	Type.	Max.	Units	Test Conditions
λ peak	Peak Wavelength	Bright Red	700		nm	IF-20mA
		Super Red	660			
		Orange Red	630			
		Yellow	585			
		Yellow Green	570			
		Super Amber	610			
λ D	Dominate Wavelength	Bright Red	690		nm	IF-20mA
		Super Red	640			
		Orange Red	610			
		Yellow	580			
		Yellow Green	560			
		Super Amber	600			
Δ λ 1/2	Spectral Line Halfwit	Bright Red	45		nm	IF-20mA
		Super Red	20			
		Orange Red	45			
		Yellow	35			
		Yellow Green	30			
		Super Amber	45			
C	Capacitance	Bright Red	40		pF	VF=0V; f=1MHZ
		Super Red	45			
		Orange Red	15			
		Yellow	20			
		Yellow Green	15			
		Super Amber	15			
VF	Forward Voltage	Bright Red	2.1	2.8	V	IF-20mA
		Super Red	1.8	2.4		
		Orange Red	2.0	2.8		
		Yellow	2.0	2.8		
		Yellow Green	2.1	2.8		
		Super Amber	2.0	2.8		
IR	Reverse Current	All		10	uA	VR=5V

Absolute Maximum Ratings at TA=25°C.

Parameter	Bright Red	Super Red	Orange Red	Yellow	Yellow Green	Super Amber	Units
Power dissipation	45	110	100	85	100	100	mW
DC Forward Current	25	25	25	25	25	25	mA
Peak Forward Current	50	200	160	160	160	160	mA
Reverse Voltage	5	5	5	5	5	5	V

NOTES:

1. Operating temperature: 40°C. TO 80°C.
2. Lead soldering: 260°C for 5 seconds.